

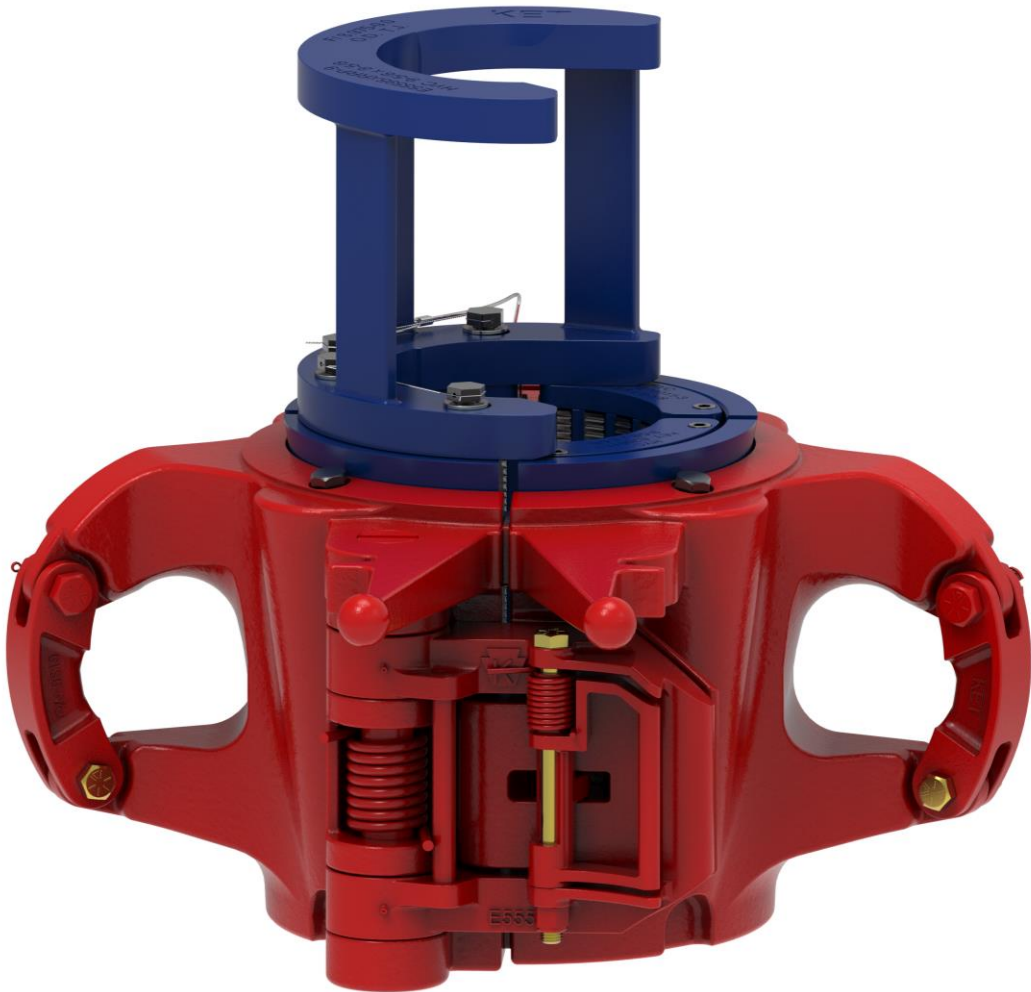

**Keystone**  
ENERGY TOOLS

# THE HYC-XR 200 TON SLIP TYPE ELEVATOR OPERATING PROCEDURE MANUAL



# Table of Contents

<b>Table of contents</b>	2
Safety instructions	3
vertical vs horizontal lifts	3
Safety instructions	4
<b>1.0 Introduction</b>	5
Figure 1 – HYC-XR model chart	5
CE Marking	5
<b>2.0 Installation</b>	5
<b>3.0 Operation</b>	7
<b>4.0 Maintenance &amp; Inspection</b>	8
Maintenance location drawing	9
<b>5.0 Repair &amp; critical areas</b>	10-13
Figure 2 & Figure 3	12
Critical area map drawing	13
Non-critical area drawing	14
<b>6.0 Technical drawings</b>	15-16
<b>7.0 HYC elevator &amp; assembly's</b>	17
<b>8.0 HYC elevator replacement parts</b>	18
<b>8.0 HYC slip replacement parts</b>	19
<b>9.0 HYC elevator wear data</b>	20
<b>10.0 Reception, storage, transport, decommissioning</b>	21
Certificate of warranty & guarantee of quality	22
Manufacture Information & Revision History	23

# "HYC" SERIES ELEVATOR

## SAFETY INSTRUCTIONS

The most important safety device for this tool is **YOU**. Your good judgment is the best protection against injury.

### ⚠ WARNING



To reduce the risk of injury, everyone using, installing, performing maintenance, changing accessories on, or working near this tool must read and understand these instructions before performing any such task.

## Operating Hazards

**⚠WARNING:** Do not overload the elevator. Overloading the recommended rating could cause series injury or death.

**⚠WARNING:** Check the latch for proper engagement. A malfunctioning latch could cause the elevator to unexpectedly unlatch or not latch at all and could result in injury or death.

**⚠WARNING:** Always insure that the elevator and slips are correct for the tubular it is to be used on. Failure to use the proper elevator and slips could result in injury or death.

**⚠WARNING:** Always ensure that the tool joint or collar O.D. of the pipe is correct. Failure to maintain adequate contact area could result in injury or death.

**⚠WARNING:** To prevent injury or elevator malfunction, inspect the elevator slips, inserts, setting plate, retainer plate, retainer screws, slip bolts, setting plate bolts, bushings, latch, hinge pin, and latch pin regularly for wear. Failure to inspect these parts could cause injury or death.

**⚠WARNING:** Do not use undersized pipe. Using undersized pipe could cause an inadequate load bearing area and uneven stress distribution. Both of which may result in injury or death.

**⚠WARNING:** Do not use the elevator if the latch or latch lock pin is malfunctioning. Latch or latch lock pin failure, may result in injury or death.

**⚠WARNING:** All warning labels attached to the equipment must be observed. The warning labels must be present on the tool. Do not remove the labels. If they are missing, replacing is mandatory.

**⚠WARNING:** The company operating the tool is responsible for issuing work instructions for safe and proper use of the equipment.

**⚠WARNING:** The operating company is responsible for verifying that any personnel operating, servicing, inspecting, or otherwise involved with the use of the tool must be properly trained correctly.

**⚠WARNING:** Do not use oversized pipe. Using oversized pipe could make it difficult or impossible to properly latch the elevator.

## Vertical / Non-vertical Lifting

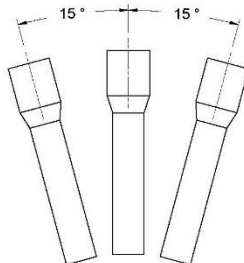

Vertical lifting is considered vertical  $\pm 15^\circ$



Non-vertical lifting is considered  $\leq 75^\circ$  as max. from horizon.

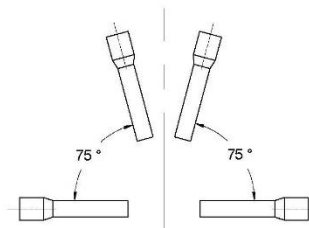

Figure 1

DO NOT DISCARD – GIVE TO USER

Keystone ENERGY TOOLS

# "HYC" SERIES ELEVATOR

## SAFETY INSTRUCTIONS

The most important safety device for this tool is **YOU**. Your good judgment is the best protection against injury.

### ⚠ WARNING



To reduce the risk of injury, everyone using, installing, performing maintenance, changing accessories on, or working near this tool must read and understand these instructions before performing any such task.

### Workplace Hazards

**⚠WARNING:** keep hands/fingers clear of the elevator bore when installing the elevator around the pipe.

**⚠WARNING:** Always use the proper tools and wear eye, head, hand, and foot protection when servicing this elevator.

**⚠WARNING:** Maintain a balanced body position and secure footing.

**⚠WARNING:** For professional use only.

### Maintenance Hazards

**⚠WARNING:** Use only Keystone Energy Tool components on equipment. Failure to do so may affect the correct functioning of the tool and may cause injury or death.

**⚠WARNING:** KET equipment is made of cast alloy heat treated steel and should never be welded on in the field. Improper welding can cause cracks or brittleness in the castings which could result in drastic weakening or failure of the equipment. Any welding or machining must be performed by an authorized KET or API certified repair center.

**⚠WARNING:** Improper welding and/or re-machining of cast alloy heat treated steel can cause personnel injury, property damage, or death.



Read Operation manual before use.



Pay attention: do not place your hands between moving parts.



DO NOT lift from this area.



Be careful when lifting from these areas.



# 1.0 Introduction

This technical manual contains operation and maintenance instructions for Keystone “HYC” series, slip-type, center latch, manual elevator with assembly drawings and complete parts breakdown. It provides a guide for proper field use, disassembling, and repair.

The Keystone “HYC-XR” series elevator is designed to be used on casing with smaller diameter couplings that is not possible with a traditional side door elevators.

With a casing specific riser setting plate made to your exact casing requirements, the riser setting plate, acting like a traditional setting plate, except the casing encounters the top riser plate, setting the slips low enough ensuring full insert contact on the casing and not the coupling.

They are balanced making them easy to handle and easy to latch on and take off at any point below the collar. The “HYC-XR” series elevator incorporates a four-slip interlocking gripping mechanism assuring of uniform grip with minimum marking to the tubular. All Keystone elevators are made up of high alloy, heat treated, steel construction, and designed to meet or exceed API specifications.

The “HYC-XR” series elevator include safety features such as guarded operating handles to help prevent accidents to operators and an extra handle at the rear of the elevator for easier, safer operation.

The “HYC-XR” elevators incorporate a latch and safety latch lock combination. The size range of the “HYC” series elevator is as illustrated in the table provided. **See figure 1**

Model	Tons	Range
<b>HYC-XR</b>	<b>200</b>	<b>7 5/8" - 9 5/8"</b>

**Figure 1**

**NOTE:** WARNING labels have been installed at critical areas on the tool. Familiarize yourself with their message and locations before proceeding to operate equipment.

**See Safety Instructions Page 4**

**⚠WARNING:** During use, the elevator should never be run into the tool joints or couplings inducing any type of shock load into the equipment. Shock loads are an impact-type force applied over a short instant of time. In shock loading, the energy of the applied force is ultimately absorbed, or transferred, to the elevator designed to resist the force. The application of shock loads to an elevator can cause shock/fatigue stress loading potentially resulting in premature stress/fatigue failure.



## CE Marking

The tool complies with the Machinery Directive 98/37/EC and 2006/42/EC

This operating manual is a part of the technical documentation for the product.

The EC Declaration of Conformity is delivered together with the product. Keep these instructions and the associated documents for later use.

## 2.0 Installation

As with any manual operated elevator, the “HYC” series elevator is easily installed on the links. Before installing ensure that the correct size of elevator, slip assembly, setting ring, and inserts are installed for the tubular being run. After using a tugger line or cat line to lift the elevator onto the rig floor and position it next to the rotary table, perform the following procedure:

- ▶ Remove cotter pins and nuts from the bottom link block bolts and then remove the bolts from the elevator.
- ▶ Lift the bottom of the link blocks and hook the small end of the links through the link blocks and link arms.
- ▶ Lower the link blocks and re-install the link block bolts, nuts and cotter pins.

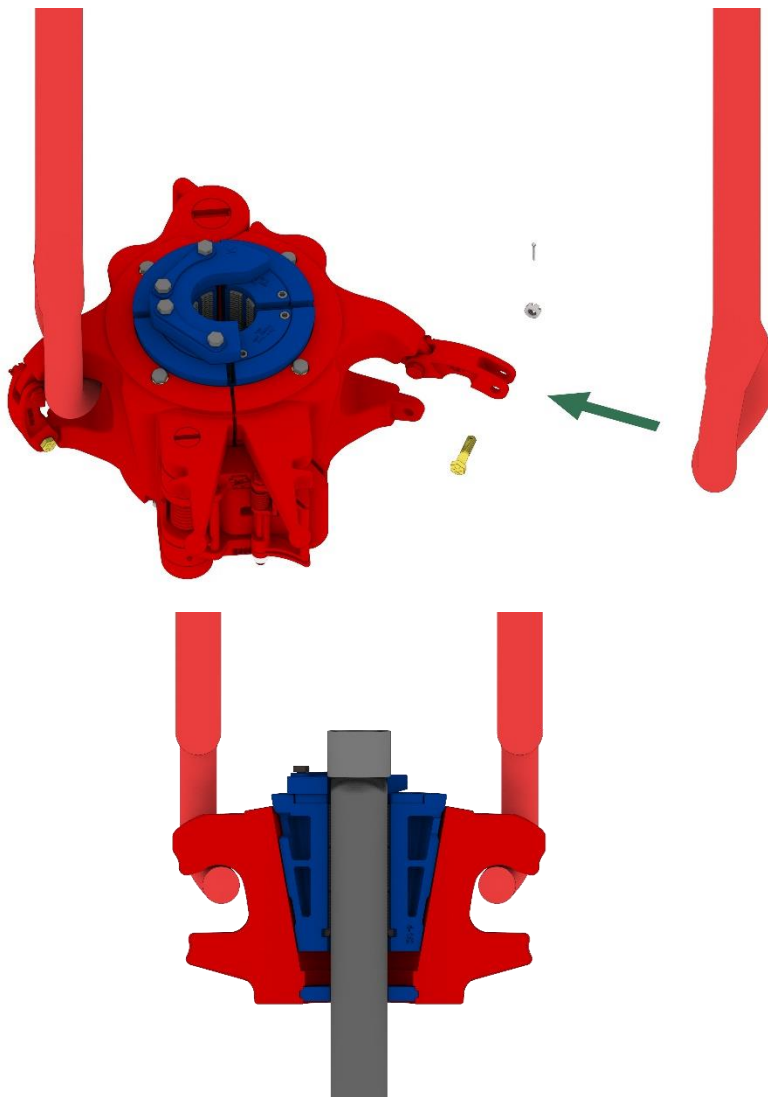

## 3.0 Operation

Operation of the elevator is straight forward. The door is opened by gripping the latch lock and pulling outward. This automatically releases the latch and latch lock assembly so the elevator can be positioned on the pipe. When the elevator is properly closed around the pipe, the latch locks automatically (see caution). The slips set when the elevator is raised and the riser setting ring makes contact with the collar which pushes the slips down in the elevator bore. To open the elevator, ensure that there is no load on the elevator and that the slips are not under any load, then simply pull the latch lock handle out and swing the elevator halves apart. When making or breaking connections always ensure that the slips are released (in the raised position). Once the connection is finished then the load can be re-applied.

### **NEVER ROTATE PIPE WITH THE SLIPS SET**

- ▶ “HYC-XR” series elevators should only be used with the proper size setting ring and inserts for the tubular they are being used on.
- ▶ Elevators are manufactured to operate at rated capacity in a vertical direction. When used to pick up or lay down a single joint of pipe in a non-vertical position, the operator must ensure that the latch, safety latch & latch springs are in good working order and that the elevator is fully latched. Prior to hoisting with the elevator from any position, it is necessary to ensure that the elevator is completely installed around the pipe and that the latches are properly engaged. Failure to do this could result in serious injury.
- ▶ Be sure to use the handles provided for operating the elevator. Keep hands and fingers clear of the elevator bore when installing the elevator on the tool joint.
- ▶ Make sure all slip segments are free and in the up position when latching the elevator. If any of the segments are stuck in the down position, the elevator will not close properly.
- ▶ Oversized pipe could cause difficulties in latching or possibly result in the elevator latching partially or not at all. Undersized pipe will cause the slips to not set properly and possibly allow the tool joint to slip through the elevator.
- ▶ Always inspect the inserts and setting ring for proper size and wear, a wrong size or worn riser setting ring or inserts could allow the pipe to become wedged or fall through the elevator.
- ▶ Inspect the bore, latch, latch pin and hinge pin regularly for wear.
- ▶ Make sure link block bolts are retained with nuts and cotter pins.



## 4.0 Maintenance & Inspection

**PRACTICE SAFETY AT ALL TIMES WHEN SERVICING THE EQUIPMENT AND USE APPROVED SAFETY METHODS, MATERIAL AND TOOLS. ALWAYS WEAR PROTECTIVE GEAR FOR EYES, HEAD, AND HANDS.**

**TO INSURE OPTIMUM PERFORMANCE FROM THE “Y” SERIES ELEVATORS, THE FOLLOWING CHECKS SHOULD BE PERFORMED BY A PERSON KNOWLEDGEABLE OF THE EQUIPMENT AND ITS FUNCTION, A MINIMUM OF:**

### **DAILY:**

- ▶ Visually inspect for cracks, loose fits or connections, elongation of parts, and other signs of wear, corrosion or overloading.
- ▶ Loose or missing components, deterioration, proper lubrication, and adjustment.
- ▶ Check for worn hinge pin, latch pin, and latch lock pin. These may inhibit proper closing of the door and latch lock engagement.
- ▶ Check slip springs, rubber bushings, inserts for wear.
- ▶ Check slip setting ring for wear and damage in the setting area.
- ▶ Check for proper operation of latch stop mechanism. The latch should not stop against door when closed but have no more than  $\frac{1}{4}$ " of standoff from the door.
- ▶ Check springs for damage or lack of tension.
- ▶ Check link block bolts for nuts and cotter pins.

**\*Note: After every job, a full NDT inspection of the setting plate should be completed. If any indications are found the setting plate is no longer acceptable for continued use.**

### **EVERY 6 MONTHS:**

- ▶ This inspection should include everything that is done in the daily inspection plus.
- ▶ A full NDT inspection of all primary-load carrying components as defined by the manufacturer.
- ▶ Inspect for excessive wear, cracks, flaws and deformations.

To perform the 6 month inspection all foreign material such as dirt, paint, grease, oil, scale, etc. shall be removed from the elevator by a suitable method of either, grit blasting, or paint stripping and steam cleaning.

### **FREQUENCY OF INSPECTIONS:**

The owner/user of the equipment should develop schedules of inspection based upon experience, the manufactures recommendations, and one or more of the following factors.

- ▶ Environment
- ▶ Load cycles
- ▶ Regulatory requirements
- ▶ Operating time
- ▶ Testing
- ▶ Repairs
- ▶ Remanufacture



# 4.0 Maintenance & Inspection

Lubricate the elevator regularly during usage and when in storage to prevent corrosion. Use an extreme pressure, multi-purpose, lithium base grease of no. 1 or no. 2 consistency and multi-weight motor oil. When the elevator is in use, lubricate according to the following schedule.

**\*\*\*When greasing of pins make sure the pump grease until it comes out of both ends.\*\*\***

## DAILY:

- ▶ Grease hinge pin
- ▶ Lubricate latch pin and latch lock pin
- ▶ Grease underside of the lifting eyes
- ▶ Check link block bolts for nuts and cotter pins

## WEEKLY:

- ▶ Brush Grease on springs
- ▶ Grease link retainer fasteners
- ▶ Check link block bolts for nuts and cotter pins
- ▶ Grease Bore
- ▶ Grease the backs of the slips

# Maintenance Locations

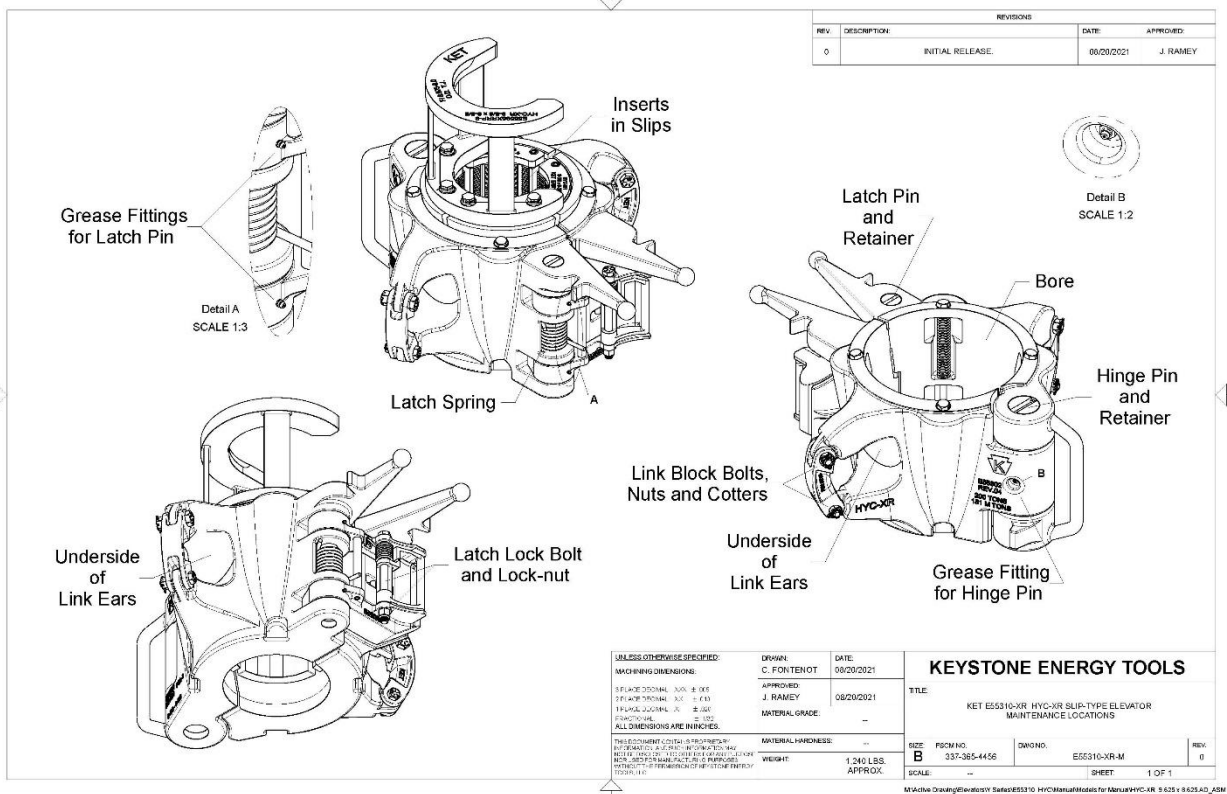

**Keystone** ENERGY TOOLS

## 5.0 Repair & Critical Areas

All “HYC-XR” series elevators are designed with incorporated lock bars to retain the hinge & latch pins.

### INSERT REPLACEMENT

**Always wear eye protection when removing or replacing inserts to protect against chip fragments.**

#### TO REMOVE WORN INSERTS OR CHANGE SIZES:

- ▶ Remove the riser slip setting ring, bushings, and insert retainer plates.
- ▶ Using a brass punch and hammer, drive out the inserts from the bottom of the slip.
- ▶ Clean and grease the insert slots before installing new inserts.

**Important: Install the correct size inserts for the casing used.**

#### SLIP INSERTION AND REMOVAL:

- ▶ Open the elevator fully and clean the slip taper and spring pockets.
- ▶ Clean the slips if necessary and grease the taper portion of the slip body.
- ▶ Insert the slip springs into the spring pocket leaving the inner edge of the spring exposed.
- ▶ Starting on the left side of the elevator and proceeding counter clockwise, insert assembled slip bodies into the elevator one at a time. Compress the edge of the slip spring with the bottom of the top lug on the slip back and ease it into the upper spring pocket.
- ▶ Then insert the slip retaining pin or bolt through the top of the elevator, slip body lug and into the slip spring. Do not insert the pin or bolt completely through the spring until both pins retain their respective slip body and slip spring.

- ▶ Once both slip pins or bolts are in place then screw retaining bolts into place.
- ▶ Make sure the proper size of inserts are loaded into the slip segments and then place an insert retainer plate into each slip.
- ▶ Place the riser slip setting ring over the slips on the left hand side of the elevator. Attach the slip setting ring to the slip segments with rubber bushings, washers and setting plate bolts. (Note: the setting ring must be placed on the left side of the elevator to avoid obstructing the casing entering the elevator).
- ▶ Secure the insert retainer plates with the insert retainer screws on the right side of the elevator.
- ▶ Tighten all insert retainer screws. Then tighten the riser setting plate bolts leaving approximately 1/16 inch play between the riser slip setting ring and its corresponding insert retainer plate as provided by the bushing. (Important: all setting plate bolts and insert retainer screws retaining the slip setting ring and insert retainers must be secured with safety wire to keep them from backing out. Stainless Steel 3/32” safety wire is (recommended). (See Figure 2)
- ▶ The riser setting plate must be secured with a cable to the rear handle of the elevator. This will prevent the riser plate from falling to the rig floor if the setting plate bolts were sheared off. (See Figure 3)

**Important: Never exceed 20 ft. lbs. on setting plate bolt torque. Failure to do so can result in injury or death.**

#### TO PREVENT JAMMING, CHECK EACH PAIR OF SLIP BODIES FOR THE FOLLOWING:

- ▶ Free movement of slip body on guide pin.
- ▶ No interface of slip guide lug in spring recess slots.
- ▶ A gap between the slips when they are set and fully compressed.

For slip removal, the top guide plate, slip setting ring, and slip retaining bolt must be removed from the elevator.

## 5.0 Repair & Critical Areas

### “HYC” SERIES DISASSEMBLE PROCEDURE

- ▶ “HYC” series latch pins are retained by dowel pins that must be removed before driving out latch pin. Drive out latch pin from bottom of elevator.
- ▶ To remove the latch lock pin, remove dowel pins and drive out latch lock pin. Remove cotter key and drive out the latch lock pin.
- ▶ Remove the hinge pin by driving it out from the bottom of the elevator, shearing the lock bar in the process and remove the latch pin in the same manner. As an alternative method, the lock bar can be drilled in the center, then split by using a chisel and removed. In either case the lock bar must be discarded.
- ▶ To remove the link block, remove cotter keys from the link block bolts and unscrew link lock bolts.
- ▶ If the door lug pin is damaged, drive or press it out from the bottom of the lug.
- ▶ Inspect all parts for damage, wear, and cracks and replace as required. It is recommended that the springs be replaced at this time.
- ▶ Reassembling is the reverse of disassembling.
- ▶ Install new lock bars and or dowel pins on hinge & latch pins.
- ▶ After assembly, ensure that full spring tension is available to close the latch & latch lock. The latch spring should contact the latch cam and or latch stop which in turn transmits the spring force to the latch.
- ▶ Check the latch for proper engagement with the door lug pin by holding the body and door apart (such that the latch contacts the lug on the door) and attempt to pry the latch open. After minimal travel of the latch the hook on the latch lock should engage with the door lug pin stopping the travel of the latch.
- ▶ Check link block bolts, nuts, & cotter pins

### KEYSTONE ENERGY TOOLS, FACTORY TOOL REPAIR.

Worn or damaged elevators are returned to like new condition with factory repair procedures based upon API 8B Specification. When tools are received for repair, they are disassembled, dimensionally checked and undergo a magnetic particle inspection. Worn areas are repaired by welding or replacing with new parts, and then heat-treated to original hardness specifications. They are proof load tested and undergo another magnetic particle inspection 24 hours after load test. They are then reassembled, functionally tested and re-certified.

### CAUTION:

- ▶ Do not use any elevator if the latch and latch lock do not function properly.
- ▶ Use only parts manufactured and sold by Keystone Energy Tools or one of KET’s authorized distributors.
- ▶ Re-machining and re-heat treating should be performed only by KET or at a KET approved repair facility. Improper machining could result in increased stress or improper alignment of the component parts. Either condition could be hazardous to personnel and equipment.
- ▶ Due to the complex metallurgy used in KET elevators, welding should be done only at KET or a KET approved repair facility.
- ▶ Bodies, doors, and latches are specifically matched by KET professionals. For this reason, a body, door and or latch from one elevator should never be exchanged with parts from another elevator.
- ▶ Always wear eye protection and the proper clothing when grinding, striking, or handling parts.
- ▶ Make sure link block bolts have nuts and cotter pins.
- ▶ If the load rating of the elevator is ever exceeded for any reason the elevator should immediately be removed from service and returned to the manufacturer for evaluation.

## 5.0 Repair & Critical Areas

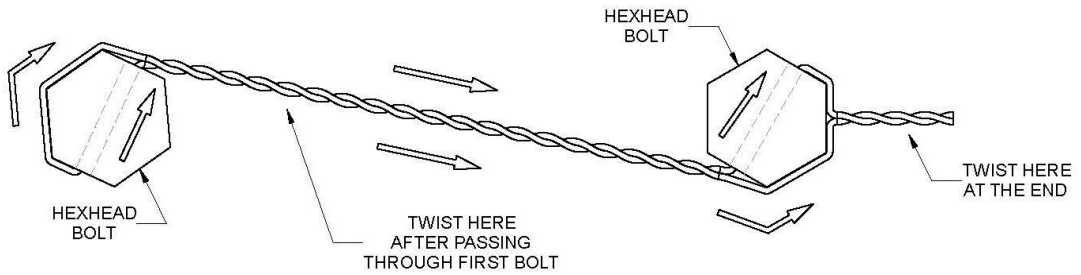

Figure 2

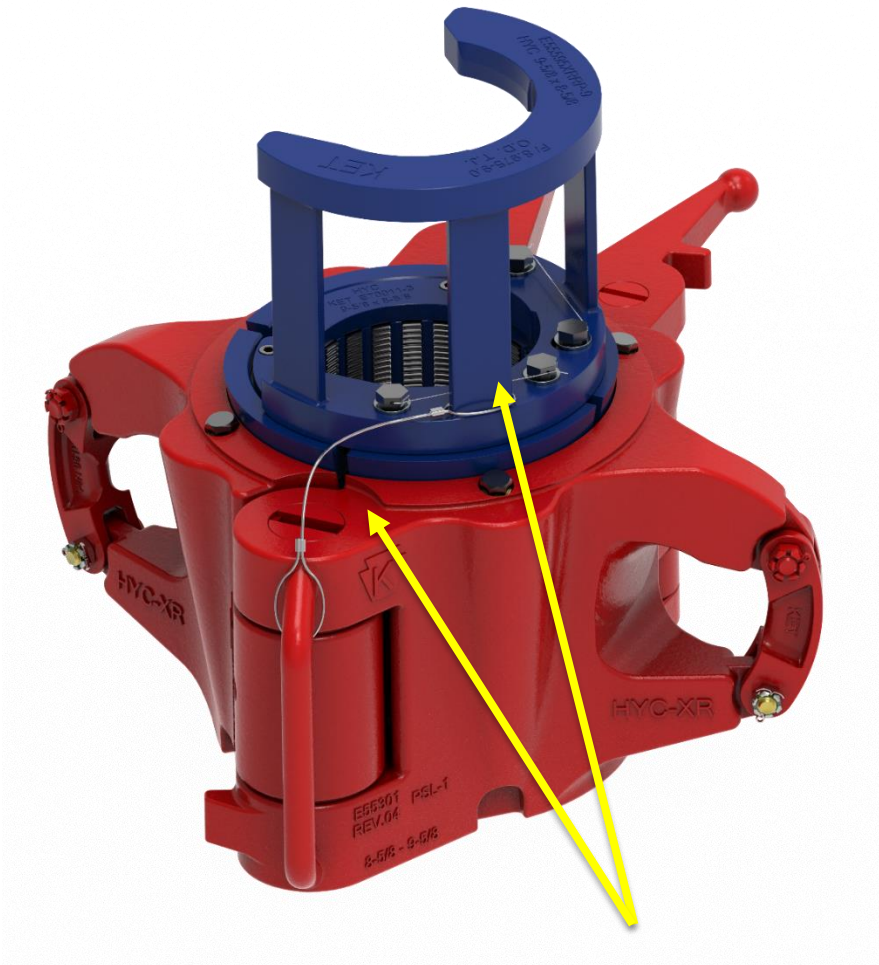

Figure 3

Safety Wire is securing the Riser Setting Plate to the rear handle of the elevator.

# 5.0 Repair Critical Areas

REVISIONS			
REV.	DESCRIPTION	DATE	APPROVED
0	INITIAL RELEASE	05/02/2021	J. RAMEY

AREAS HATCHED ARE CONSIDERED CRITICAL AREAS.  
AREAS NOT HATCHED ARE CONSIDERED NON-CRITICAL AREAS.

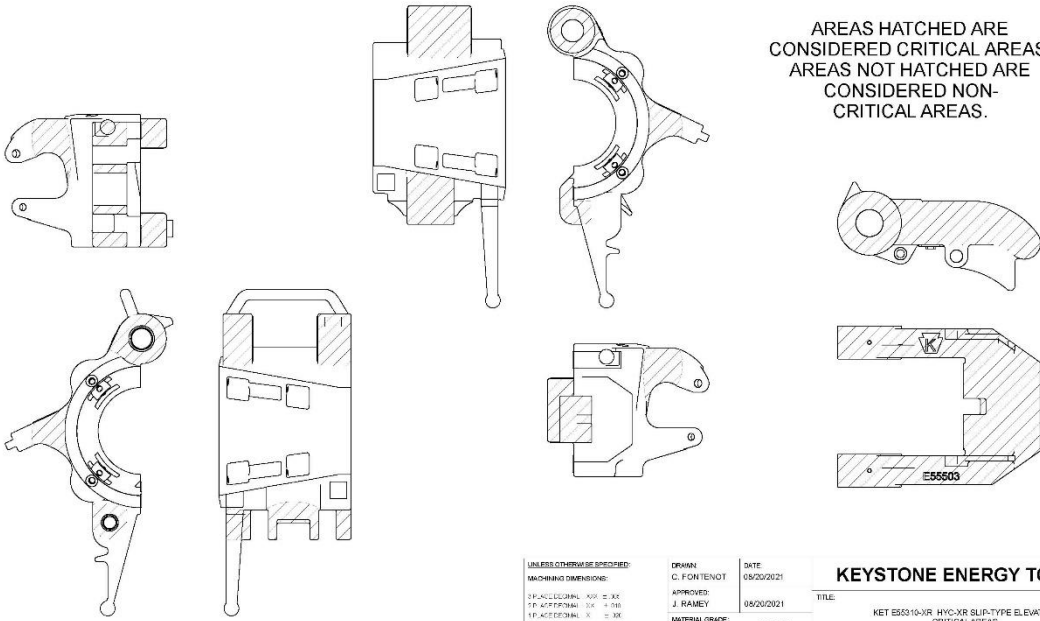

UNLESS OTHERWISE SPECIFIED: MACHINING DIMENSIONS: 2 PLACE DECIMAL .XX ± .XX 3 PLACE DECIMAL .XXX ± .003 4 PLACE DECIMAL .XXXX ± .0005 FRACTIONS: 1/16, 1/8, 3/16, 1/4, 3/8, 1/2, 5/8, 3/4, 7/8, 1 ALL DIMENSIONS ARE IN INCHES.		DRAWN: C. FORTENOT DATE: 05/20/2021 APPROVED: J. RAMEY DATE: 05/20/2021 MATERIAL GRADE: MS-004	<b>KEYSTONE ENERGY TOOLS</b> TITLE: KET E5510-XR HVC-XR SLIP-TYPE ELEVATOR CRITICAL AREAS SIZE: B PRODMNO: 337-305-4455 DWGNO: E5510-XR-C WEIGHT: -- SCALE: -- SHEET: 1 OF 1
---	--	--	---

REVISIONS			
REV.	DESCRIPTION	DATE	APPROVED
0	INITIAL RELEASE	02/02/2021	J. RAMEY

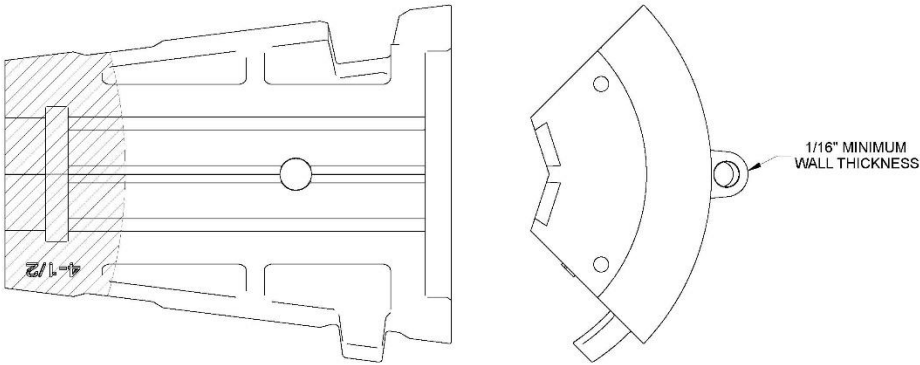

AREAS HATCHED ARE CONSIDERED CRITICAL AREAS.  
AREAS NOT HATCHED ARE CONSIDERED NON-CRITICAL AREAS.

UNLESS OTHERWISE SPECIFIED: MACHINING DIMENSIONS: 2 PLACE DECIMAL .XX ± .XX 3 PLACE DECIMAL .XXX ± .003 4 PLACE DECIMAL .XXXX ± .0005 FRACTIONS: 1/16, 1/8, 3/16, 1/4, 3/8, 1/2, 5/8, 3/4, 7/8, 1 ALL DIMENSIONS ARE IN INCHES.		DRAWN: C. FORTENOT DATE: 02/02/2021 APPROVED: J. RAMEY DATE: 02/02/2021 MATERIAL GRADE: MS-004	<b>KEYSTONE ENERGY TOOLS</b> TITLE: KET HVC SLIP SEGMENT CRITICAL AREAS SIZE: B PRODMNO: 337-305-4455 DWGNO: E5511-C WEIGHT: -- SCALE: -- SHEET: 1 OF 1
---	--	--	--



# 6.0 Non-Critical Areas

The below illustration shows the parts of the assembly that are exempt from volumetric examination.

SHOWN ARE PARTS AND AREAS THAT ARE EXEMPT FROM N.D.E.

REVISIONS			
REV.	DESCRIPTION:	DATE:	APPROVED:
0	INITIAL RELEASE.	08/20/2021	J. RAMEY

UNLESS OTHERWISE SPECIFIED:  
MACHINING DIMENSIONS:

3 PLACE DECIMAL: .XXX ± .005  
2 PLACE DECIMAL: .XX ± .010  
1 PLACE DECIMAL: .X ± .020  
FRACTIONAL: ± .1/32  
ALL DIMENSIONS ARE IN INCHES.

THIS DOCUMENT CONTAINS PROPRIETARY INFORMATION, AND SUCH INFORMATION MAY NOT BE DISCLOSED TO OTHERS FOR ANY PURPOSE NOR USED FOR MANUFACTURING PURPOSES WITHOUT THE PERMISSION OF KEYSTONE ENERGY TOOLS, LLC.

DRAWN: C. FONTENOT	DATE: 08/20/2021	<b>KEYSTONE ENERGY TOOLS</b>	
APPROVED: J. RAMEY	08/20/2021		
MATERIAL GRADE: --			
MATERIAL HARDNESS: --		TITLE:	KET E55310-XR HYC-XR BOTTLENECK ELEVATOR NON-CRITICAL PARTS AND AREAS
WEIGHT: 1,240 LBS. APPROX.	SIZE <b>A</b>	FSCM NO. 337-365-4456	DWG NO. E55310-XR-NC
		SCALE: --	REV. 0
		SHEET: 1 OF 1	

M:\Active Drawing\Elevators\Y Series\E55310 HYCManualModels for Manual\HYC-XR 9.625 x 8.625 AD\_ASM

# 6.0 Technical Drawings

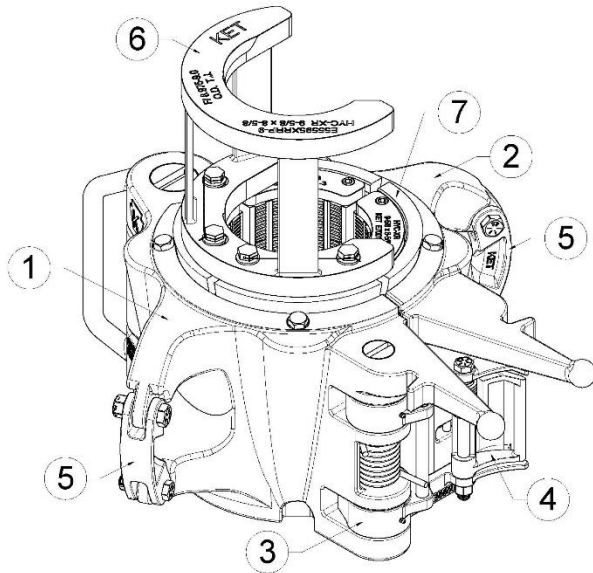

REVISIONS			
REV.	DESCRIPTION	DATE	APPROVED
0	INITIAL RELEASE	08/20/2021	J. RAMEY

1. ELEVATOR BODY
2. ELEVATOR DOOR
3. LATCH
4. LATCH LOCK
5. LINK BLOCK
6. RISER SETTING RING
7. SLIP ASSEMBLY (x4)

UNLESS OTHERWISE SPECIFIED: MACHINING DIMENSIONS: Ø FINISHES: 200 & 405 25 PLACE DECIMAL: .001 15 PLACE DECIMAL: .005 FINISHES: .0005 ALL DIMENSIONS ARE IN INCHES. THIS DOCUMENT IS THE PROPERTY OF KEYSER ENERGY SERVICES AND IS NOT TO BE REPRODUCED OR TRANSMITTED IN ANY FORM OR BY ANY MEANS, ELECTRONIC OR MECHANICAL, INCLUDING PHOTOCOPYING, RECORDING, OR BY ANY INFORMATION STORAGE AND RETRIEVAL SYSTEM.		DRAWN: C. FORNITENOT	DATE: 08/20/2021	<b>KEYSTONE ENERGY TOOLS</b>	
		APPROVED: J. RAMEY	08/20/2021		
		MATERIAL GRADE: -		TITLE: KET E55310-XR HYC-XR SLIP-TYPE ELEVATOR MAIN COMPONENTS	
		MATERIAL HARDNESS: -		SIZE: B	FIGING NO.: 237-385-445B
		WEIGHT: 1,240 LBS. APPROX.		DWG NO.: E55310-XR-A	REV: 0
				SCALE: 1:1.5	SHEET: 1 OF 1

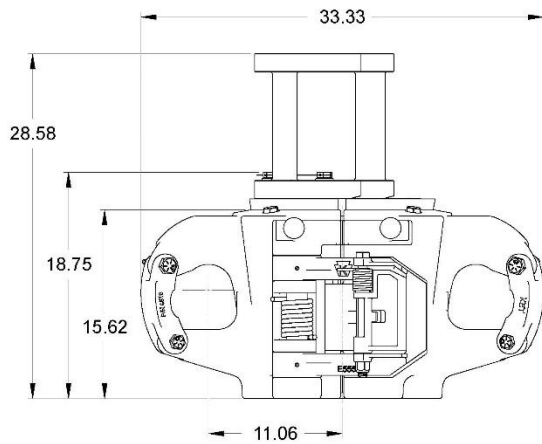
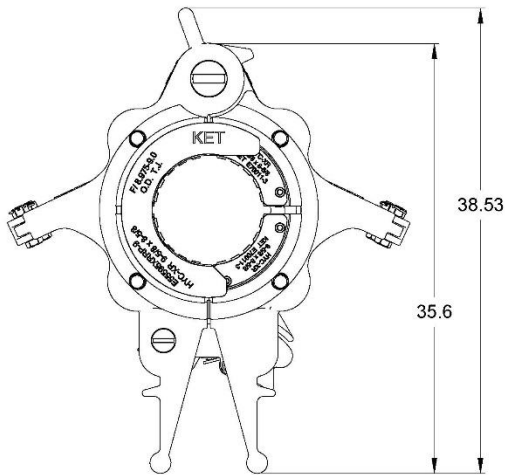

REVISIONS			
REV.	DESCRIPTION	DATE	APPROVED
0	INITIAL RELEASE	08/20/2021	J. RAMEY

UNLESS OTHERWISE SPECIFIED: MACHINING DIMENSIONS: Ø FINISHES: 200 & 405 25 PLACE DECIMAL: .001 15 PLACE DECIMAL: .005 FINISHES: .0005 ALL DIMENSIONS ARE IN INCHES. THIS DOCUMENT IS THE PROPERTY OF KEYSER ENERGY SERVICES AND IS NOT TO BE REPRODUCED OR TRANSMITTED IN ANY FORM OR BY ANY MEANS, ELECTRONIC OR MECHANICAL, INCLUDING PHOTOCOPYING, RECORDING, OR BY ANY INFORMATION STORAGE AND RETRIEVAL SYSTEM.		DRAWN: C. FORNITENOT	DATE: 08/20/2021	<b>KEYSTONE ENERGY TOOLS</b>	
		APPROVED: J. RAMEY	08/20/2021		
		MATERIAL GRADE: -		TITLE: KET E55310-XR HYC-XR SLIP-TYPE ELEVATOR APPROXIMATE SIZE DIMENSIONS	
		MATERIAL HARDNESS: -		SIZE: B	FIGING NO.: 237-385-445B
		WEIGHT: 1,240 LBS. APPROX.		DWG NO.: E55310-XR-D	REV: 0
				SCALE: 1:1.8	SHEET: 1 OF 1

M:\china Drawing\Energy\97\96\95310 HYC\Main\Mech\Main HYC-XR 8 825 & 835 AD\_ASM



# 6.0 Technical Drawings

REVISIONS			
REV.	DESCRIPTION	DATE	APPROVED
0	INITIAL RELEASE	06/20/2021	J. RAMEY

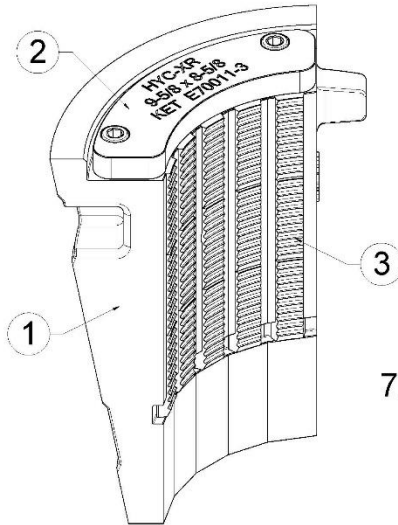

1. SLIP SEGMENT
2. INSERT RETAINER
3. INSERT (x15)

7.625" - 9.625"

UNLESS OTHERWISE SPECIFIED		DRAWN	DATE	KEYSTONE ENERGY TOOLS	
MACHINING DIMENSIONS:		C. FON TENOT	08/20/2021	TITLE:	
FRACTIONAL: 1/16" 3/32"		APPROVED		KET-HYC-XR SLIP SEGMENT	
DECIMAL: .005" .010"		J. RAMEY	08/20/2021	MAIN COMPONENTS	
TOLERANCES ARE UNLESS OTHERWISE SPECIFIED		MATERIAL GRADE:	..	SIZE:	REV.
THIS DOCUMENT IS THE PROPERTY OF KEYSOURCE AND IS TO BE RETURNED TO KEYSOURCE UPON REQUEST. NO PARTS OR INFORMATION FROM THIS DOCUMENT ARE TO BE REPRODUCED OR TRANSMITTED IN ANY FORM OR BY ANY MEANS, ELECTRONIC OR MECHANICAL, INCLUDING PHOTOCOPYING, RECORDING, OR BY ANY INFORMATION STORAGE AND RETRIEVAL SYSTEM.		MATERIAL HARDNESS:	..	PSG NO:	0
		WEIGHT:	..	DWG NO:	
				E55511-XR-A	
				SCALE:	SHEET: 1 OF 1

# 7.0 HYC-XR Slip Type Elevator & Assemblies

PART NUMBER	DESCRIPTION	SIZE OF LINKS	WEIGHT(lbs.)
E55310-XR	HYC ELEVATOR LESS SLIP ASSEMBLY	2-1/4" - 3-1/2"	1200.00



## HYC SLIP ASSEMBLIES

PART NUMBER	DESCRIPTION	WEIGHT(lbs.)
E70009	7" X 7 5/8" HYC SLIP ASSY.	265.00
E70009-1	7 5/8" HYC SLIP SEGMENTS ONLY (MATCHED SET OF 4)	200.00

## HYC SETTING RINGS

PART NUMBER	DESCRIPTION	# REQ.	WEIGHT(lbs.)
E70012	7 5/8" HYC SETTING RING	1	11.00
E55522	7" HYC SETTING RING	1	11.50
E55521	6 5/8" HYC SETTING RING	1	12.00
E55520	5 1/2" HYC SETTING RING	1	13.00
E55519	5" HYC SETTING RING	1	14.50
E55518	4 1/2" HYC SETTING RING	1	15.00
E55517	4" HYC SETTING RING	1	16.50
E55516	3 1/2" HYC SETTING RING	1	18.00

## HYC BOTTOM GUIDE PLATES

PART NUMBER	DESCRIPTION	# REQ.	WEIGHT(lbs.)
E24071-6	7 5/8" BOTTOM GUIDE PLATE	1	5.02
E24071-2	7" BOTTOM GUIDE PLATE	1	3.75
E24071-3	6 5/8" BOTTOM GUIDE PLATE	1	4.50
E24071-1	5 1/2" BOTTOM GUIDE PLATE	1	5.50
E24071	5" BOTTOM GUIDE PLATE	1	7.75
E24071-4	4 1/2" BOTTOM GUIDE PLATE	1	8.50
E26827	4" BOTTOM GUIDE PLATE	1	8.50
E26827-1	3 1/2" BOTTOM GUIDE PLATE	1	8.00

# 8.0 HYC-XR Replacement Parts

REVISIONS		DATE:	APPROVED:
REV. 0	DESCRIPTION: INITIAL RELEASE	02/02/2021	J. RAMEY

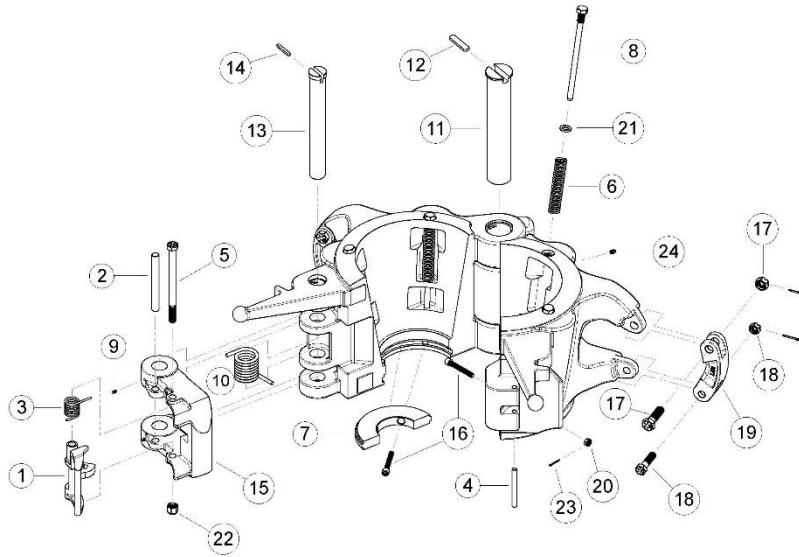

UNLESS OTHERWISE SPECIFIED:  
 MACHINING DIMENSIONS:  
 FINISHES:  
 ALL DIMENSIONS ARE IN INCHES.

THIS DOCUMENT IS UNCLASSIFIED UNLESS INDICATED OTHERWISE.  
 ALL INFORMATION CONTAINED HEREIN IS UNCLASSIFIED EXCEPT WHERE SHOWN OTHERWISE.  
 DATE OF DECLASSIFICATION: 01/01/2040

DRAWN: C. FONTENOT	DATE: 02/02/2021	<b>KEYSTONE ENERGY TOOLS</b>	
APPROVED: J. RAMEY	02/02/2021	TITLE: KET E85310 HYC SLIP-TYPE ELEVATOR PARTS BREAKDOWN	
MATERIAL GRADE: --	MATERIAL HARDNESS: --	DWG NO: E85310-B	REV: 0
WEIGHT: 1.300 LBS. APPROX.	SCALE: 1:1	SHEET: 1 OF 1	

MTW21w Drawing/Elevator/SlipType/E85310 HYCManuf/E85310-B HYC Parts Breakdown\_AD\_A04

ITEM NUMBER	PART NUMBER	DESCRIPTION	QTY
1	E13152	LATCH LOCK	1
2	E13185	SPRING STOP PIN	1
3	E13188	LATCH LOCK SPRING	1
4	E13190	DOOR LUG PIN	1
5	E15101	LATCH LOCK BOLT	1
6	E945044-2	SLIP SPRING	4
7	BOTTOM GUIDE PLATE	SEE CHART ON PAGE 14	
8	E24076	SLIP BOLT	4
9	E940308-1	GREASE ZERT F/LATCH	2
10	E34909	LATCH SPRING	1
11	E55311	HINGE PIN	1
12	E55504	HINGE PIN RETAINER	1
13	E55312	LATCH PIN	1
14	E55505	LATCH PIN RETAINER	1
15	N/A	N/A	N/A
16	E55508	BOTTOM GUIDE PLATE BOLTS	4
17	E8145-1	UPPER LINK BLOCK BOLT, NUT, & COTTER	2
18	E8145-2	LOWER LINK BLOCK BOLT, NUT, & COTTER	2
19	E9519	LINK BLOCK	2
20	E939484-5	CASTLE NUT F/GUIDE PLATE BOLT	4
21	E939354-6	LOCK WASHER FOR SLIP BOLT	4
22	E8150	LOCK NUT F/LATCH LOCK BOLT	1
23	E939672-17	COTTER PIN F/CASTLE NUT ON GUIDE PLATE BOLT	4
24	E940308-1	GREASE ZERT F/HINGE	1

**Keystone** ENERGY TOOLS

# 8.0 HYC-XR Slip Replacement Parts

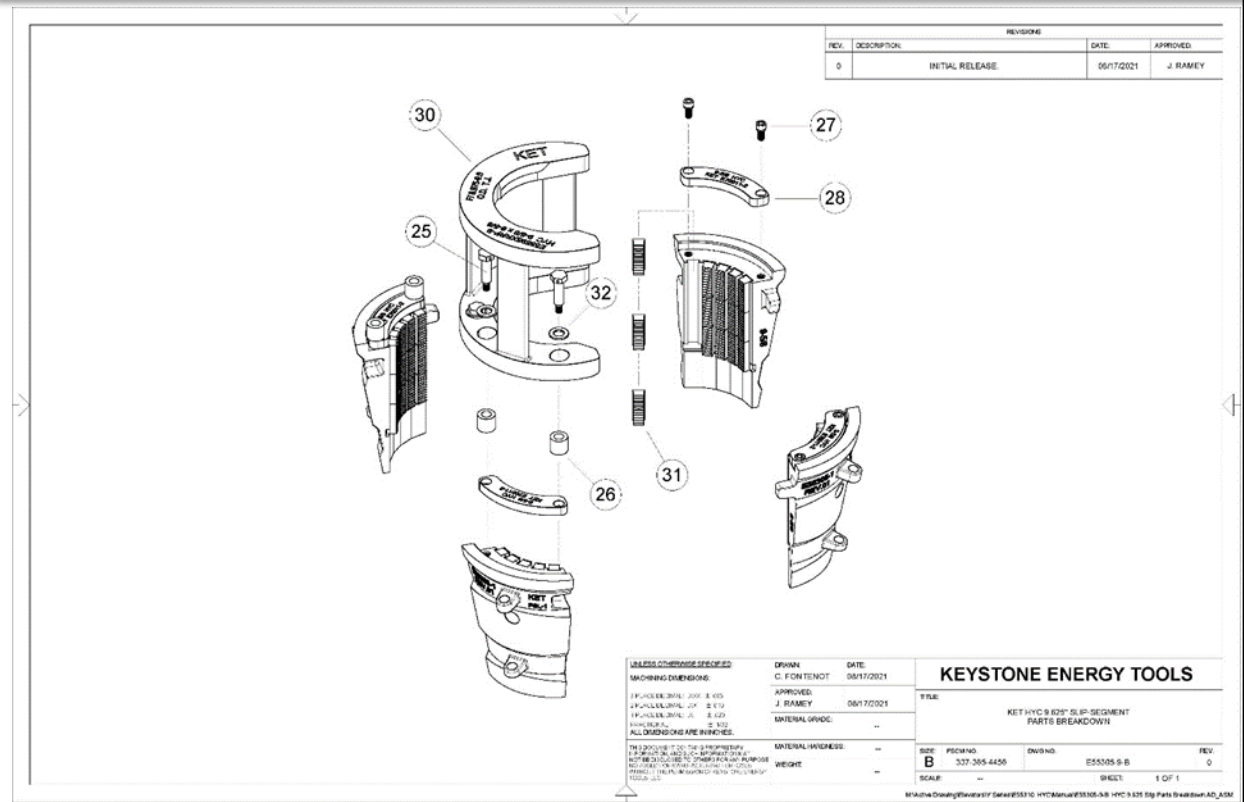

ITEM NUMBER	PART NUMBER	DESCRIPTION	QTY
25	E55501	SETTING PLATE BOLT	4
26	E55502	RUBBER BUSHING	4
27	E941271-73	INSERT RETAINER SCREWS	4
28	E70011	7 5/8" INSERT RETAINER	4
28	E30230	7" INSERT RETAINER	4
28	E30224	5 1/2" INSERT RETAINER	4
28	E30214	4 1/2" - 3 1/2" INSERT RETAINER	4
29	E30216	SETTING RING RETAINER (3 1/2" - 7")	2
29	E70147	SETTING RING RETAINER (7 5/8")	2
30	SETTING PLATE	SEE CHART ON PAGE 14	1
32	E55502-W	WASHER F/SETTING PLATE BOLT	4

## INSERTS

ITEM NUMBER	PART NUMBER	DESCRIPTION	QTY
31	E16408	4 1/2" X 4 1/2" BASIC INSERT	16
31	E16407	5 1/2" - 7 5/8" BASIC INSERT	16
31	E24781	4 1/2" X 4" YC INSERT	16
31	E24779	4 1/2" X 3 1/2" YC INSERT	16
31	E24783	5 1/2" X 5" YC INSERT	16
31	E24785	5 1/2" X 4 1/2" YC INSERT	16
31	E24748	7" X 6 5/8" YC INSERT	24

# 9.0 HYC Wear Data

PART NUMBER	E55310-XR
RATED CAPACITY	200 TON

## STANDARD PINS

HINGE PIN PART #	E55311
TOTAL CLEARANCE(H)	0.045
HINGE PIN MIN. DIA. NEW	2.869
BORE DIA.MAX. NEW	2.878
BORE DIA.MAX.WORN	2.900

LATCH PIN PART #	E55312
TOTAL CLEARANCE(L)	0.045
LATCH PIN MIN. DIA. NEW	1.745
BORE DIA.MAX.NEW	1.752
BORE DIA.MAX.WORN	1.775

## 1/16" OVERSIZE PINS

HINGE PIN PART #	E55311-06
TOTAL CLEARANCE(H)	0.045
HINGE PIN MIN. DIA. NEW	2.931
BORE DIA.MAX. NEW	2.940
BORE DIA.MAX.WORN	2.963

LATCH PIN PART #	E55312-06
TOTAL CLEARANCE(L)	0.045
LATCH PIN MIN. DIA. NEW	1.994
BORE DIA.MAX.NEW	2.002
BORE DIA.MAX.WORN	2.025

## 1/8" OVERSIZE PINS

HINGE PIN PART #	E55311-12
TOTAL CLEARANCE(H)	0.045
HINGE PIN MIN. DIA. NEW	2.994
BORE DIA.MAX. NEW	3.002
BORE DIA.MAX.WORN	3.025

LATCH PIN PART #	E55312-12
TOTAL CLEARANCE(L)	0.045
LATCH PIN MIN. DIA. NEW	2.056
BORE DIA.MAX.NEW	2.065
BORE DIA.MAX.WORN	2.088

## LIFTING EARS

DIMENSION (W) MIN	3.625
RADIUS -R	2.000
DIMENSION (M)	11.063

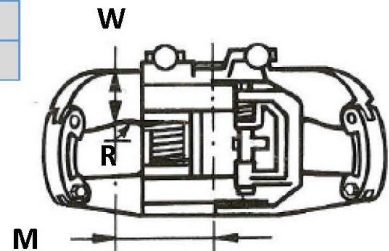
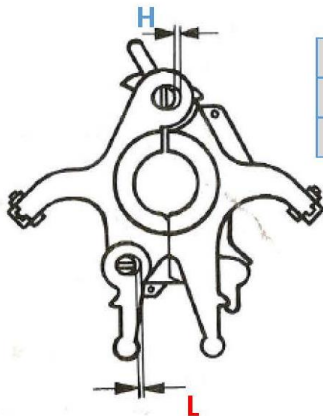

# 10.0 Reception, Storage, Transport & Decommissioning

## Reception

Check the tool immediately after reception and re-preserve the tool as required (try to have this completed within 1 month).

Any exposed or non painted metal surfaces should be coated with a rust preventative to prevent any corrosion build up.

## Storage

The tool should be stored or palletized in a clean and dry place to avoid all environmental elements. It is recommended to store in an indoor environment of 60 – 70 Deg F with max humidity of 80%. If the tool is to be stored outdoor, then a cargo container would be appropriate to ensure the tool is not exposed to weather conditions.

Preserve the tool by greasing all areas defined in the maintenance requirements per the manual.

During storage, the tool shall still be inspected annually per inspection requirements in the user's manual.

## Transport

When lifting the tool do so only by using its lifting ears only. The best way of transporting the tool is in its original palletized state. Ensure the tool is banded down accordingly to prevent the possibility of potential dropped objects and broken shipments.

## Decommissioning

The tool may contain grease, steel, rubbers, plastic, stainless steel, mild steel and several assembled components with undefined consistency or mixtures. The tool can be contaminated with drilling fluids, hydraulic fluids and preservatives. After the tool is decommissioned, it is recommended to disassemble the tool in a place where waste fluids can be contained and properly disposed of.

**⚠WARNING:** any fluids, mud, or grease are potentially unsafe when in contact with the skin. Always wear gloves and safety goggles when disassembling the tool.

1. Clean the tool with a steam cleaner.
2. It is recommended to disassemble the tool in a place where drainage for waste fluids is possible.

## CERTIFICATE OF WARRANTY AND GUARANTEE OF QUALITY

KET warrants all materials and products manufactured to be free from defects in material and workmanship, under normal use and service, when installed, used, and serviced in the manner provided and intended by the seller for a period of twelve (12) months after delivery. Seller's obligation under this warranty is expressly limited to repair or replacement, at its option, of any materials or products, returned to the seller's plant in New Iberia, Louisiana and which are determined by the seller to be defective. All freight charges for return and reshipment shall be paid by the customer. A new warranty period shall not be established for repaired or replaced material or products; such items shall remain under warranty only for the remainder of the warranty period on the original materials or products. This is the sole warranty of the seller and no other warranty is either expressed or implied, in fact or by law, including any warranty as to the merchantability or fitness for a particular use or purpose.

In case of goods or parts not wholly of seller's manufacture, seller shall make available to the customer whatever warranty or guarantee is extended to seller for such goods or parts by the supplier or manufacturer thereof.

Seller will not assume responsibility or liability for any repairs, rebuilding, welding or heat treating done to its material or products outside of seller's plant, such work shall void all warranties. All parts used in the manufacture and /or final assembly of seller's materials or products are necessary for both safety and operational performance. Omission of any part or failure to replace any worn part may result in the malfunction and a consequent safety hazard for which seller disclaims any responsibility or liability for injuries or damage as a result thereof.

Buyer's sole and only remedy in regard to any defective materials or products shall be the repair or replacement thereof as herein provided, and seller shall not be liable for any consequential, special, incidental or punitive damages resulting from or caused by any defective materials, products or supplies.





*For more information, please contact us at:*

**Keystone Energy Tools**  
3711 Melancon Rd.  
Broussard, LA 70518

[www.k-e-t.com](http://www.k-e-t.com)

**Office:** 1-337-365-4411  
**Fax:** 1-337-365-4456

#### Revision History

Rev	Date	Changes	By
0	05/26/2021	Original release	Cody H.
01	03/11/2022	Changed figure 2 to 3 and added new figure 2 wire tie diagram	Cody H.
02	07/19/2022	Updated address	Cody H.
03	01/09/2023	Updated title page	Cody H.
04	05/16/2023	Added item #32 P/N E55502-W	Cody H.
05	04/08/2024	Added warning about shock loading	Cody H.