



Keystone
ENERGY TOOLS

THE SLX 150 TON SQUARE SHOULDER ELEVATOR OPERATING PROCEDURE MANUAL



Table of Contents

Table of contents	2
Safety instructions	3
vertical vs horizontal lifts	3
Safety instructions	4
1.0 Introduction	5
Figure 1 – SLX-150 model chart	5
CE Marking	5
2.0 Operation	5
3.0 Maintenance	6
Figure 2 – maintenance locations	6
3.0 Maintenance & Inspection	7
Figure 3 – maintenance frequency chart	7
4.0 Repair Critical area drawings	8
Figure 4 – critical area map	8
5.0 Technical drawings	9
6.0 Replacement parts	10
7.0 Wear data	11
8.0 Wear Data	12
9.0 Wear Data	13
10.0 Wear Data	14
11.0 Reception, Storage, Transport & Decommissioning	15
Certificate of warranty & guarantee of quality	16
Manufacture Information & Revision History	17

"SLX" SERIES ELEVATOR

SAFETY INSTRUCTIONS

The most important safety device for this tool is **YOU**. Your good judgment is the best protection against injury.

⚠ WARNING



To reduce the risk of injury, everyone using, installing, performing maintenance, changing accessories on, or working near this tool must read and understand these instructions before performing any such task.

Operating Hazards

⚠WARNING: Do not overload the elevator. Overloading the recommended rating could cause series injury or death.

⚠WARNING: Secure the Latch Lock Pin in its proper position. Failure to secure the pin when picking up or laying down pipe could cause serious injury or death.

⚠WARNING: Always ensure that the elevator and bore code are correct for the tubular it is to be used on. Failure to use the proper elevator and bore code could result in injury or death.

⚠WARNING: Always ensure that the tool joint or collar O.D. of the pipe is correct. Failure to maintain adequate contact area could result in injury or death.

⚠WARNING: To prevent injury or elevator malfunction, inspect the elevator bore, latch, hinge pin, and latch pin regularly for wear. Failure to inspect these parts could cause injury or death.

⚠WARNING: Do not use oversized pipe. Using oversized pipe could make it difficult or impossible to properly latch the elevator.

⚠WARNING: Do not use undersized pipe. Using undersized pipe could cause an inadequate load bearing area and uneven stress distribution. Both of which may result in injury or death.

⚠WARNING: Do not use the elevator if the latch or latch lock pin is malfunctioning. Latch or latch lock pin failure, may result in injury or death.

⚠WARNING: All warning labels attached to the equipment must be observed. The warning labels must be present on the tool. Do not remove the labels. If they are missing, replacing is mandatory.

⚠WARNING: The company operating the tool is responsible for issuing work instructions for safe and proper use of the equipment.

⚠WARNING: The operating company is responsible for verifying that any personnel operating, servicing, inspecting, or otherwise involved with the use of the tool must be properly trained correctly.

Vertical / Non-vertical Lifting

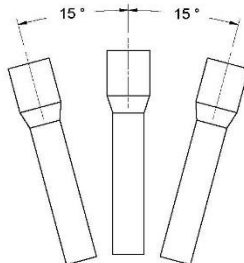

Vertical lifting is considered vertical $\pm 15^\circ$



Non-vertical lifting is considered $\leq 75^\circ$ as max. from horizon.

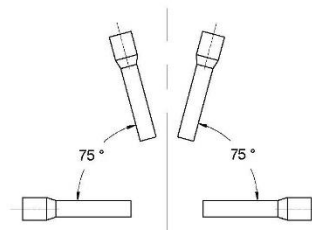

"SLX" SERIES ELEVATOR

SAFETY INSTRUCTIONS

The most important safety device for this tool is **YOU**. Your good judgment is the best protection against injury.

⚠ WARNING



To reduce the risk of injury, everyone using, installing, performing maintenance, changing accessories on, or working near this tool must read and understand these instructions before performing any such task.

Workplace Hazards

⚠WARNING: keep hands fingers clear of the elevator bore when installing the elevator around the pipe.

⚠WARNING: Always use the proper tools and wear eye, head, hand, and foot protection when servicing this elevator.

⚠WARNING: Maintain a balanced body position and secure footing.

⚠WARNING: For professional use only.

Maintenance Hazards

⚠WARNING: Use only Keystone Energy Tool components on equipment. Failure to do so may affect the correct functioning of the tool and may cause injury or death.

⚠WARNING: KET equipment is made of cast alloy heat treated steel and should never be welded on in the field. Improper welding can cause cracks or brittleness in the castings which could result in drastic weakening or failure of the equipment. Any welding or machining must be performed by an authorized KET or API certified repair center.

⚠WARNING: Improper welding and/or re-machining of cast alloy heat treated steel can cause personnel injury, property damage, or death.



Read Operation manual before use.



Pay attention: do not place your hands between moving parts.



DO NOT lift from this area.



Be careful when lifting from these areas.



1.0 Introduction

This manual contains operation and maintenance instructions for the Keystone Energy Tools (KET) “SLX-150” series, Square Shoulder Side Door Elevators for handling casing or drill collars with assembly drawings and complete parts breakdown. It provides a guide for proper field use, disassembling and repair.

(KET) “SLX-150” series elevators are designed to be used with casing or drill collars. They are balanced making them easy to handle as well as easy to latch on or take off at any point below the upset or collar of the pipe. “SLX-150” series elevators are made of high alloy-heat treated steel and designed to meet or exceed API specifications.

The “SLX-150” series elevator includes safety features such as guarded operating handles to help prevent injury to operators and an extra handle at the rear of the elevator for easier, safer operation. The “SLX-150” series elevators incorporate a latch and safety latch lock combination, there is also a secondary safety lock system in the form of a spring pin. The size range of the “SLX-150” series elevator is as illustrated in the table provided.

(See Figure 1)

Model	Tons	Range
E31150	SLX-150	2 7/8” – 5 3/4”
E31239	SLX-150	4 1/2” – 8 5/8”
E33950	SLX-150	9 5/8” – 10 3/4”
E33982	SLX-150	11 3/4” – 14”

Figure 1

NOTE **⚠WARNING** labels have been installed at critical areas on the tool. Familiarize yourself with their message and locations before proceeding to operate equipment.

See Safety Instructions Page 4

⚠WARNING: During use, the elevator should never be run into the tool joints or couplings inducing any type of shock load into the equipment. Shock loads are an impact-type force applied over a short instant of time. In shock loading, the energy of the applied force is ultimately absorbed, or transferred, to the elevator designed to resist the force. The application of shock loads to an elevator can cause shock/fatigue stress loading potentially resulting in premature stress/fatigue failure.



CE Marking

The tool complies with the Machinery Directive 98/37/EC and 2006/42/EC

This operating manual is a part of the technical documentation for the product.

The EC Declaration of Conformity is delivered together with the product. Keep these instructions and the associated documents for later use.

2.0 Operation

As with any manual operated elevator, the “SLX-250” series is easily installed by the user. Perform the actions described below after the elevator is hoisted to the rig floor and properly positioned.

- ▶ Remove cotter pins and nuts from the bottom link block bolts and then remove the bolts from the elevator.
- ▶ Lift the bottom of the link blocks and hook the small end of the links through the link blocks and link arms.
- ▶ Lower the link blocks and re-install the link block bolts, nuts and cotter pins.

The operation of the “SLX-250” series elevator is straightforward. The door is opened by gripping the latch lock and pulling outward. This automatically releases the latch and latch lock assembly so the elevator can be positioned on the pipe. When the elevator is properly closed around the pipe, the latch locks automatically.

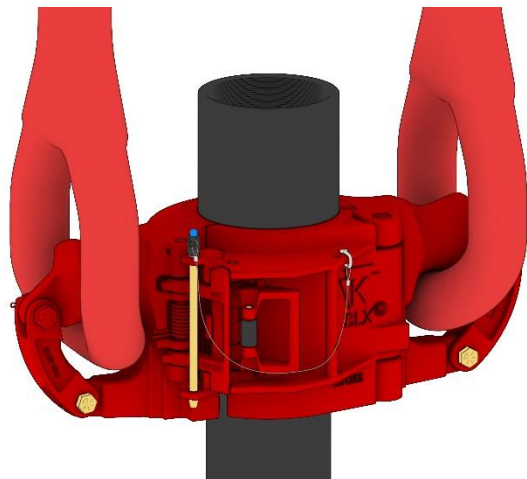
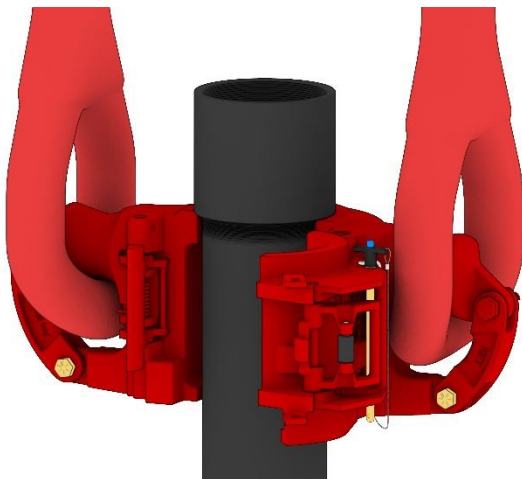
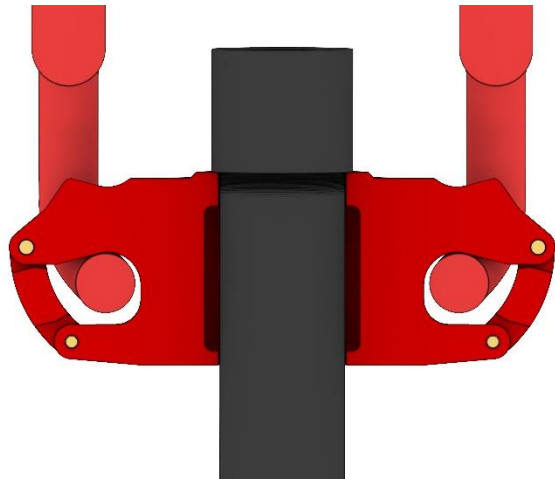

3.0 Maintenance

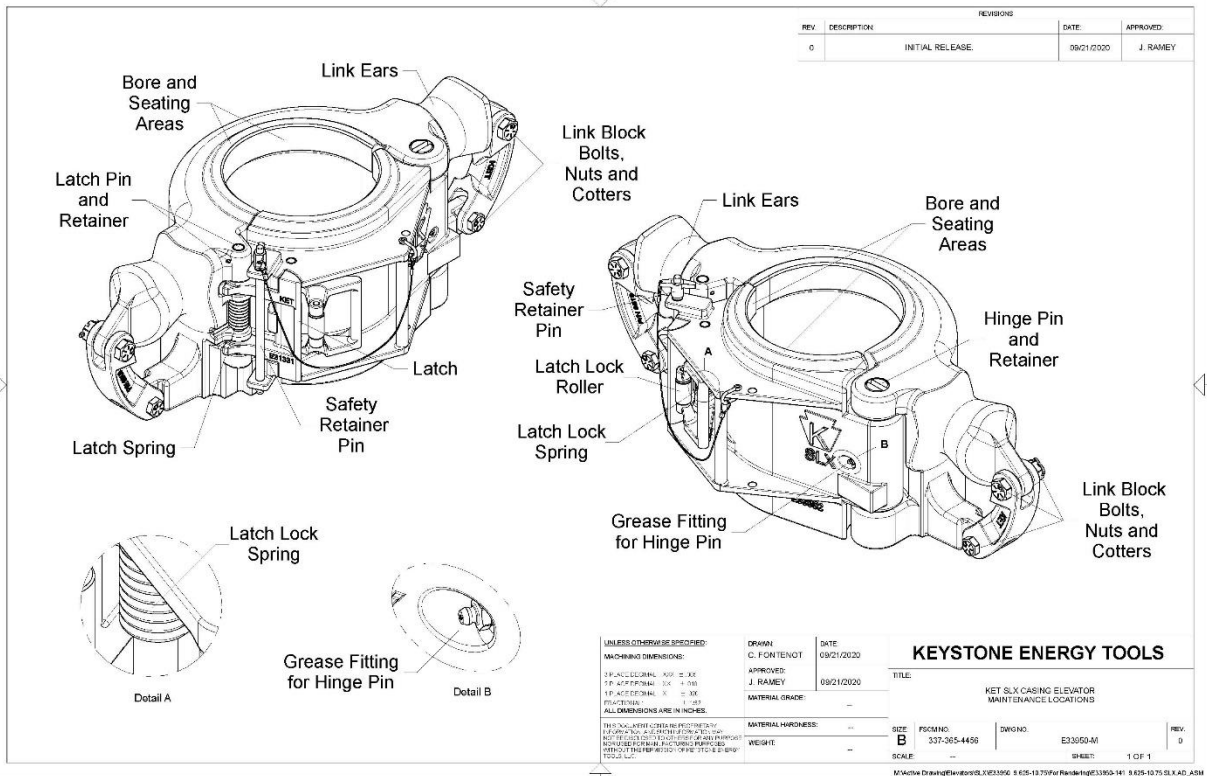

Figure 2

To ensure optimum performance, perform the below-listed weekly checks. (See Figure 2)

- Check for worn Hinge Pin and Latch Pin and their mating parts. These, if worn, may hinder proper opening and closing of the door and latch.
- Check the Latch Lock Pin assembly for worn or damaged parts. (e.g. Safety Latch Pin)
- Check for proper Latch Spring performance.
- Check for proper operation of Latch Stop mechanism. Latch should not stop against the door when engaged.
- Check springs for damage, deformation and lack of tension.

Lubricate the elevator regularly during usage and storage to prevent corrosion. Use an extreme pressure, multi-purpose, lithium base grease of No. 1 or No. 2 consistency or a lubricant that meets MIL-SPEC-A907E.

3.0 Maintenance & Inspection

The owner/user of the equipment should develop schedules of inspection based upon experience, manufactures recommendations, and one or more of the following factors:

- ▶ Environment
- ▶ Load Cycles
- ▶ Regulatory requirements
- ▶ Operating time
- ▶ Testing
- ▶ Repairs
- ▶ Remanufacture

Proof Load Test shall be performed only once following manufacture or remanufacture. This is by applying a load equal to 1.5 times the rated load for a period no less than 5 min. A proof load test shall be followed by surface NDT no earlier than 24 hrs. after proof of testing.

Lubricate the elevator regularly during usage and storage to prevent corrosion. Use an extreme pressure, multi-purpose, lithium base grease of No. 1 or No. 2 consistency or a lubricant that meets MIL-SPEC-A907E.

When greasing of pins make sure the pump grease until it comes out of both ends.

Maintain elevator as prescribed in the below periodic Actions/Examinations. (See Figure 3)

Figure 3

Reference API 8B Recommended Practice

Every 12 months the equipment **shall** be disassembled to permit the necessary full NDT inspection of all primary load carrying components per ASTM E-709 (see figure 5). Including inspection for excessive wear, cracks, flaws , and deformations.

If any repair work is required, the equipment shall be sent into a Keystone Energy Tool facility for evaluation.

“Performance Load Test” is recommended after 365 days of accumulative use. This test is to verify the function of the equipment to perform under the conditions or in conjunction with other equipment. The Performance Test may consist of loads up to, but not exceeding, the rated load of the equipment.

Tool Maintenance		
ACTION	FREQUENCY	FIG.
Grease Hinge Pin	Daily	6
Lubricate Latch Pin		6
Lubricate Latch Lock Bolt		6
Grease Underside of Lifting Eye		6
Grease Bore and Seating Surface		6
MPI Category III	Every 6 Months	8
MPI Category IV	Every 12 Months	8
Performance Load Test	Every 365 Days “See left”	-

4.0 Repair & Critical Areas

Disassembly Procedure

- Remove the latch assembly and latch spring by driving or pressing out the roll pin and driving out the latch pin from the bottom of the elevator.
- Remove the latch lock from the door by driving out the roll pin.
- Remove the hinge pin by driving it out from the bottom of the elevator, shearing the roll pin in the process. The roll pin must be discarded after removal.
- If either link block is to be replaced, remove the link block bolt and cotter pins.
- Reassemble by reversing the above steps.
- Install new roll pins on hinge and latch pins.
- After assembly, ensure that full spring tension is available to close the latch & lock. The latch spring should contact the spring stop bar, which in turn transmits the spring force to the latch.

- Check the latch lock for proper engagement with the latch by holding the body and door apart (such that the latch contacts the lug on the door) and attempt to pry the latch open. After minimal movement of the latch, the hook on the latch should engage with the latch, stopping the travel of the latch.
- Check link block bolts, nuts, and cotter pins.

We have identified those areas considered critical to tool performance and functionality. These should be examined for repair or replacement. (See Figure 8)

Bodies, doors and latches are specifically matched by trained Keystone Energy Tools professionals. For this reason, a body, door or latch from one elevator should never be exchanged with a body, door, or latch from another elevator.

Illustrated below, are the critical and non-critical areas associated with the subject tool. Critical areas are identified by the shaded areas. All non-shaded areas are considered non-critical.

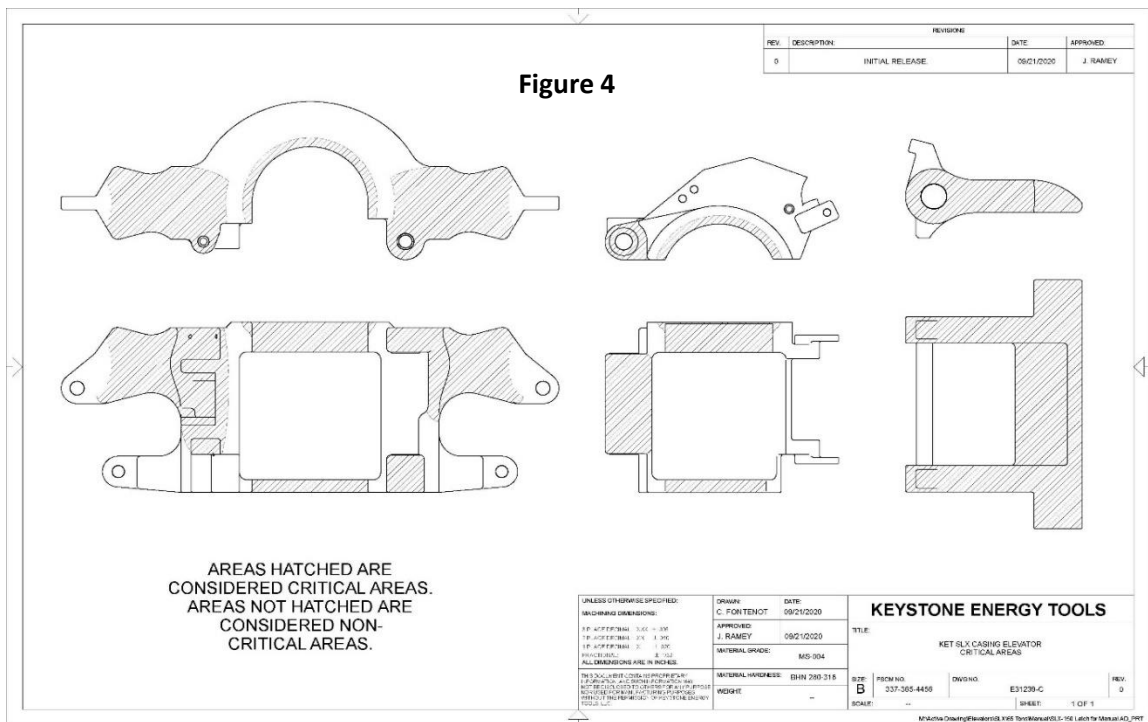

5.0 Elevator Technical Drawings

1. ELEVATOR BODY
2. ELEVATOR DOOR
3. LATCH
4. LATCH LOCK
5. LINK BLOCK

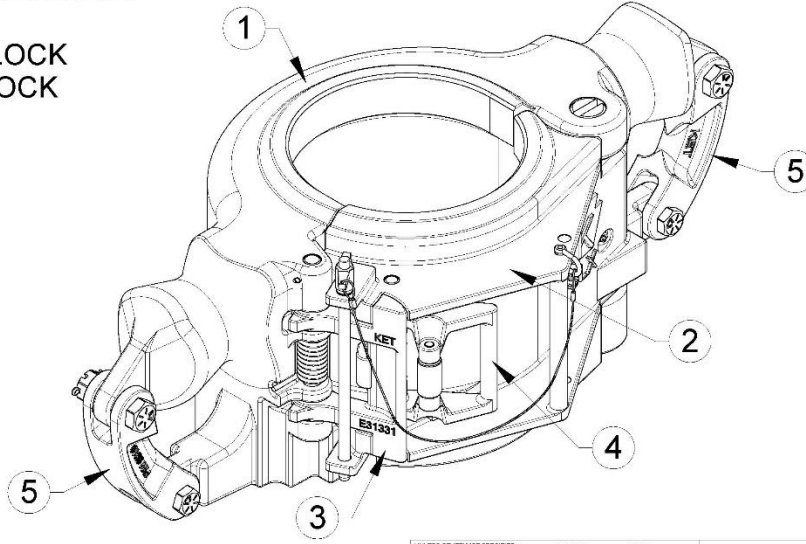

REVISIONS			
REV.	DESCRIPTION	DATE	APPROVED
0	INITIAL RELEASE	09/21/2020	J. RAMEY

***NOTE – PAINT CAN NOT EXCEED A THICKNESS OF 0.2mm**

UNLESS OTHERWISE SPECIFIED				KEYSTONE ENERGY TOOLS			
MACHINING DIMENSIONS:				DESIGN	C. F. ON TENDT	DATE	09/21/2020
2. P. UNLESS SPECIFIED				APPROVED:	J. RAMEY	DATE:	09/21/2020
3. P. UNLESS SPECIFIED				MATERIAL GRADE:	...	FILE:	KEY SLX CASING ELEVATOR MAIN COMPONENTS
4. P. UNLESS SPECIFIED				MATERIAL HARDNESS:	...	SIZE:	...
5. P. UNLESS SPECIFIED				FORM NO.	...
6. P. UNLESS SPECIFIED				ENGINO.	...
7. P. UNLESS SPECIFIED				REV.	...

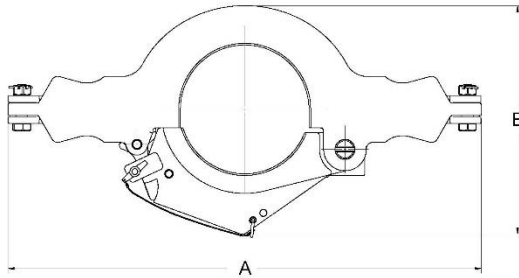

Elevator	Range	Dimension A	Dimension B	Dimension C	Dimension D	Dimension E
ES3504	2.875" - 5.5"	30"	15.06"	9"	12"	12.5"
ES1220	5" - 8.625"	33.25"	15.44"	10.66"	12"	12.2"
L33650	8.625" - 10.75"	38"	17.33"	12"	12"	12.2"
L33662	11.75" - 14"	40.5"	19"	14.25"	12"	12.2"

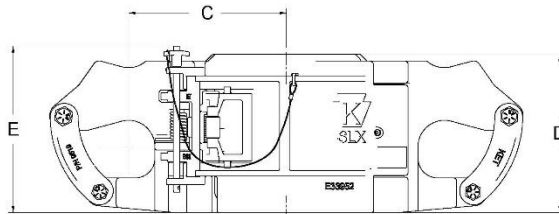

REVISIONS			
REV.	DESCRIPTION	DATE	APPROVED
0	INITIAL RELEASE	09/21/2020	J. RAMEY

UNLESS OTHERWISE SPECIFIED				KEYSTONE ENERGY TOOLS			
MACHINING DIMENSIONS:				DESIGN	C. F. ON TENDT	DATE	09/21/2020
2. P. UNLESS SPECIFIED				APPROVED:	J. RAMEY	DATE:	09/21/2020
3. P. UNLESS SPECIFIED				MATERIAL GRADE:	...	FILE:	KEY SLX CASING ELEVATOR APPROXIMATE SIZE DIMENSIONS
4. P. UNLESS SPECIFIED				MATERIAL HARDNESS:	...	SIZE:	...
5. P. UNLESS SPECIFIED				FORM NO.	...
6. P. UNLESS SPECIFIED				ENGINO.	...
7. P. UNLESS SPECIFIED				REV.	...

6.0 Replacement Parts

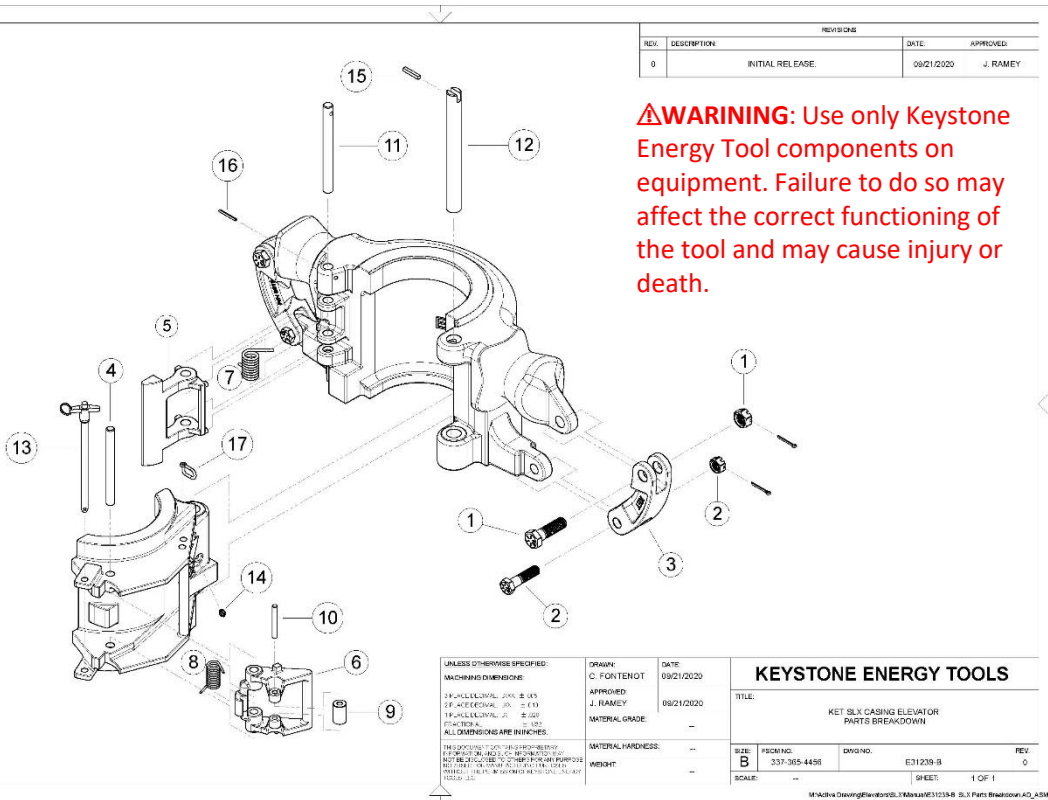

ITEM	QTY	PART No.	DESCRIPTION
1	2	E8145-1	UPPER LINK BLOCK BOLT, NUT, COTTER
2	2	E8145-2	LOWER LINK BLOCK BOLT, NUT, COTTER
3	2	E9519	LINK BLOCK
4	1	E29980-4	LATCH LOCK PIN
5	1	E31331	LATCH
6	1	E31332	LATCH LOCK
7	1	E31383	LATCH SPRING
8	1	E31404	LATCH LOCK SPRING
9	1	E31407	LATCH LOCK ROLLER
10	1	E31584	LATCH LOCK ROLLER PIN
11	1	E32424-5	LATCH PIN
12	1	E34611	HINGE PIN
13	1	E39-051-5	SAFETY LATCH LOCK PIN W/ CHAIN (not shown)
14	1	E940308-1	1/8 NPT GREASE ZERT
15	1	E34614	HINGE PIN RETAINER
16	1	E947128-120	LATCH PIN RETAINER

7.0 Wear Data for SLX Elevators

PART NUMBER	E31150
RATED CAPACITY	150 Ton

STANDARD PINS

HINGE PIN PART #	E34611
TOTAL CLEARANCE(H)	0.030
HINGE PIN DIA. NEW	1.120-1.135
BORE MAX NEW	1.125-1.145
BORE DIA.MAX.WORN	1.150

LATCH PIN PART #	E32424-5
TOTAL CLEARANCE(L)	0.030
LATCH PIN DIA. NEW	0.745-0.760
BORE DIA. NEW	0.750-0.770
BORE DIA.MAX.WORN	0.775

1/16" OVERSIZE PINS

HINGE PIN PART #	E34611-06
TOTAL CLEARANCE(H)	0.025
HINGE PIN MIN. DIA. NEW	1.183
BORE DIA.MAX. NEW	1.190
BORE DIA.MAX.WORN	1.208

LATCH PIN PART #	E32424-306
TOTAL CLEARANCE(L)	0.030
LATCH PIN MIN. DIA. NEW	0.808
BORE DIA.MAX.NEW	0.815
BORE DIA.MAX.WORN	0.833

1/8" OVERSIZE PINS

HINGE PIN PART #	N/A
TOTAL CLEARANCE(H)	N/A
HINGE PIN MIN. DIA. NEW	N/A
BORE DIA.MAX. NEW	N/A
BORE DIA.MAX.WORN	N/A

LATCH PIN PART #	N/A
TOTAL CLEARANCE(L)	N/A
LATCH PIN MIN. DIA. NEW	N/A
BORE DIA.MAX.NEW	N/A
BORE DIA.MAX.WORN	N/A

LIFTING EARS

DIMENSION (W) MIN	2.875
RADIUS-R	2.000
DIMENSION (M)	10.625

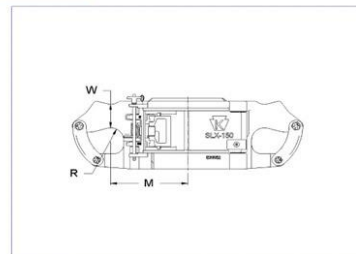
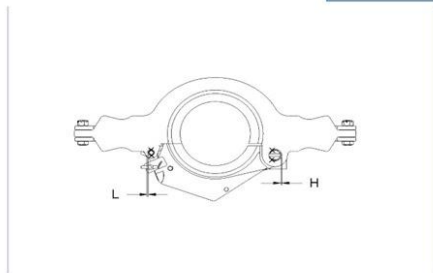

8.0 Wear Data for SLX Elevators

PART NUMBER	E31239
RATED CAPACITY	150 Ton

STANDARD PINS

HINGE PIN PART #	E34611
TOTAL CLEARANCE(H)	0.030
HINGE PIN DIA. NEW	1.120-1.135
BORE DIA. NEW	1.125-1.145
BORE DIA.MAX.WORN	1.150

LATCH PIN PART #	E32424-5
TOTAL CLEARANCE(L)	0.030
LATCH PIN DIA. NEW	0.745-0.760
BORE DIA. NEW	0.750-0.770
BORE DIA.MAX.WORN	0.775

1/16" OVERSIZE PINS

HINGE PIN PART #	E34611-06
TOTAL CLEARANCE(H)	0.025
HINGE PIN MIN. DIA. NEW	1.183
BORE DIA.MAX. NEW	1.190
BORE DIA.MAX.WORN	1.208

LATCH PIN PART #	E32424-306
TOTAL CLEARANCE(L)	0.030
LATCH PIN MIN. DIA. NEW	0.808
BORE DIA.MAX.NEW	0.815
BORE DIA.MAX.WORN	0.833

1/8" OVERSIZE PINS

HINGE PIN PART #	N/A
TOTAL CLEARANCE(H)	N/A
HINGE PIN MIN. DIA. NEW	N/A
BORE DIA.MAX. NEW	N/A
BORE DIA.MAX.WORN	N/A

LATCH PIN PART #	N/A
TOTAL CLEARANCE(L)	N/A
LATCH PIN MIN. DIA. NEW	N/A
BORE DIA.MAX.NEW	N/A
BORE DIA.MAX.WORN	N/A

LIFTING EARS

DIMENSION (W) MIN	3.687
RADIUS -R	2.000
DIMENSION (M)	10.625

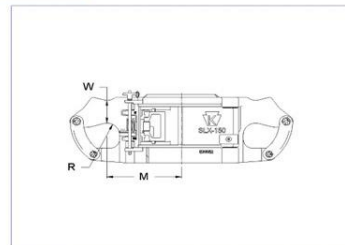
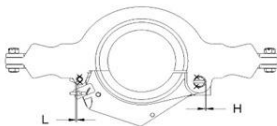

9.0 Wear Data for SLX Elevators

PART NUMBER	E33950
RATED CAPACITY	150 Ton

STANDARD PINS

HINGE PIN PART #	E33953
TOTAL CLEARANCE(H)	0.030
HINGE PIN DIA. NEW	1.495-1.510
BORE DIA. NEW	1.500-1.520
BORE DIA.MAX.WORN	1.525

LATCH PIN PART #	E32424-5
TOTAL CLEARANCE(L)	0.030
LATCH PIN MIN. DIA. NEW	0.745-0.760
BORE DIA.MAX.NEW	0.750-0.770
BORE DIA.MAX.WORN	0.775

1/16" OVERSIZE PINS

HINGE PIN PART #	E33953-06
TOTAL CLEARANCE(H)	0.030
HINGE PIN MIN. DIA. NEW	1.557
BORE DIA.MAX. NEW	1.565
BORE DIA.MAX.WORN	1.583

LATCH PIN PART #	E32424-306
TOTAL CLEARANCE(L)	0.030
LATCH PIN MIN. DIA. NEW	0.808
BORE DIA.MAX.NEW	0.815
BORE DIA.MAX.WORN	0.833

1/8" OVERSIZE PINS

HINGE PIN PART #	N/A
TOTAL CLEARANCE(H)	N/A
HINGE PIN MIN. DIA. NEW	N/A
BORE DIA.MAX. NEW	N/A
BORE DIA.MAX.WORN	N/A

LATCH PIN PART #	N/A
TOTAL CLEARANCE(L)	N/A
LATCH PIN MIN. DIA. NEW	N/A
BORE DIA.MAX.NEW	N/A
BORE DIA.MAX.WORN	N/A

LIFTING EARS

DIMENSION (W) MIN	3.687
RADIUS-R	2.000
DIMENSION (M)	10.625

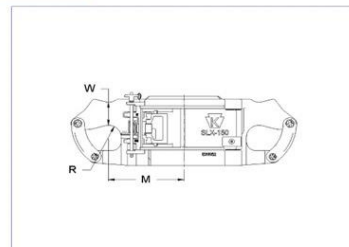
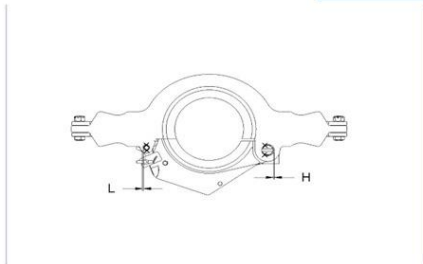

10.0 Wear Data for SLX Elevators

PART NUMBER	E33982
RATED CAPACITY	150 Ton

STANDARD PINS

HINGE PIN PART #	E33953
TOTAL CLEARANCE(H)	0.030
HINGE PIN DIA. NEW	1.870-1.885
BORE DIA. NEW	1.875-1.895
BORE DIA.MAX.WORN	1.900

LATCH PIN PART #	E32424-5
TOTAL CLEARANCE(L)	0.030
LATCH PIN DIA. NEW	0.745-0.760
BORE DIA. NEW	0.750-0.770
BORE DIA.MAX.WORN	0.775

1/16" OVERSIZE PINS

HINGE PIN PART #	E33985-306
TOTAL CLEARANCE(H)	0.030
HINGE PIN MIN. DIA.	1.932
BORE DIA.MAX. NEW	1.940
BORE DIA.MAX.WORN	1.958

LATCH PIN PART #	E32424-306
TOTAL CLEARANCE(L)	0.030
LATCH PIN MIN. DIA. NEW	0.808
BORE DIA.MAX.NEW	0.815
BORE DIA.MAX.WORN	0.833

1/8" OVERSIZE PINS

HINGE PIN PART #	N/A
TOTAL CLEARANCE(H)	N/A
HINGE PIN MIN. DIA. NEW	N/A
BORE DIA.MAX. NEW	N/A
BORE DIA.MAX.WORN	N/A

LATCH PIN PART #	N/A
TOTAL CLEARANCE(L)	N/A
LATCH PIN MIN. DIA. NEW	N/A
BORE DIA.MAX.NEW	N/A
BORE DIA.MAX.WORN	N/A

LIFTING EARS

DIMENSION (W) MIN	3.687
RADIUS -R	2.000
DIMENSION (M)	10.625

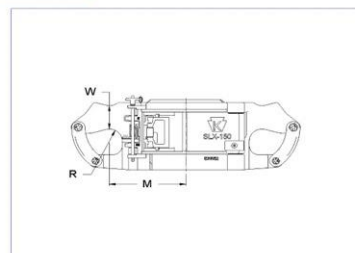
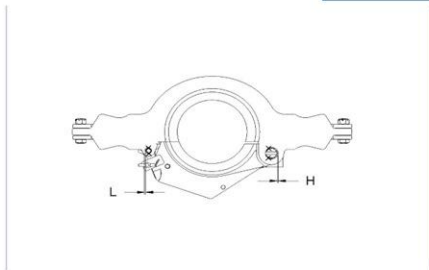

11.0 Reception, Storage, Transport & Decommissioning

Reception

Check the tool immediately after reception and re-preserve the tool as required (try to have this completed within 1 month).

Any exposed or non painted metal surfaces should be coated with a rust preventative to prevent any corrosion build up.

Storage

The tool should be stored or palletized in a clean and dry place to avoid all environmental elements. It is recommended to store in an indoor environment of 60 – 70 Deg F with max humidity of 80%. If the tool is to be stored outdoor, then a cargo container would be appropriate to ensure the tool is not exposed to weather conditions.

Preserve the tool by greasing all areas defined in the maintenance requirements per the manual.

During storage, the tool shall still be inspected annually per inspection requirements in the user's manual.

Transport

When lifting the tool do so only by using its lifting ears only. The best way of transporting the tool is in its original palletized state. Ensure the tool is banded down accordingly to prevent the possibility of potential dropped objects and broken shipments.

Decommissioning

The tool may contain grease, steel, rubbers, plastic, stainless steel, mild steel and several assembled components with undefined consistency or mixtures. The tool can be contaminated with drilling fluids, hydraulic fluids and preservatives. After the tool is decommissioned, it is recommended to disassemble the tool in a place where waste fluids can be contained and properly disposed of.

⚠WARNING: any fluids, mud, or grease are potentially unsafe when in contact with the skin. Always wear gloves and safety goggles when disassembling the tool.

1. Clean the tool with a steam cleaner.
2. It is recommended to disassemble the tool in a place where drainage for waste fluids is possible.

CERTIFICATE OF WARRANTY AND GUARANTEE OF QUALITY

KET warrants all materials and products manufactured to be free from defects in material and workmanship, under normal use and service, when installed, used, and serviced in the manner provided and intended by the seller for a period of twelve (12) months after delivery. Seller's obligation under this warranty is expressly limited to repair or replacement, at its option, of any materials or products, returned to the seller's plant in New Iberia, Louisiana and which are determined by the seller to be defective. All freight charges for return and reshipment shall be paid by the customer. A new warranty period shall not be established for repaired or replaced material or products; such items shall remain under warranty only for the remainder of the warranty period on the original materials or products. This is the sole warranty of the seller and no other warranty is either expressed or implied, in fact or by law, including any warranty at to the merchantability or fitness for a particular use or purpose.

In case of goods or parts not wholly of seller's manufacture, seller shall make available to the customer whatever warranty or guarantee is extended to seller for such goods or parts by the supplier or manufacturer thereof.

Seller will not assume responsibility or liability for any repairs, rebuilding, welding or heat treating done to its material or products outside of seller's plant, such work shall void all warranties. All parts used in the manufacture and /or final assembly of seller's materials or products are necessary for both safety and operational performance. Omission of any part or failure to replace any worn part may result in the malfunction and a consequent safety hazard for which seller disclaims any responsibility or liability for injuries or damage as a result thereof.

Buyer's sole and only remedy in regard to any defective materials or products shall be the repair or replacement thereof as herein provided, and seller shall not be liable for any consequential, special, incidental or punitive damages resulting from or caused by any defective materials, products or supplies.



For more information, please contact us at:

Keystone Energy Tools
3711 Melancon Rd.
Broussard, LA 70518

www.k-e-t.com

Office: 1-337-365-4411
Fax: 1-337-365-4456

Revision History

Rev.	Date	Changes	Revised by
06	05/26/2021	Format update/added revision history	Cody H.
07	09/22/2021	Updated SLX150 wear data f/all frames	Cody H.
08	07/19/2022	Updated address	Cody H.
09	06/01/2023	Updated the frame size for the E31239	Cody H.
10	09/18/2023	Updated wear data for E31150 ear thickness	Cody H.
11	02/04/2024	Updated wear data for each frame size	Cody H.
12	04/03/2024	Added warning about shock loading	Cody H.