



Keystone
ENERGY TOOLS

THE SINGLE JOINT BOTTLENECK & CASING ELEVATOR
OPERATING PROCEDURE MANUAL



Table of Contents

Table of contents	2
Safety instructions	3
vertical vs horizontal lifts	3
Figure 1-4 - latching elevator correctly/incorrectly	4
Safety instructions	5
1.0 Introduction	6
Figure 5 – SJ model chart	6
CE Marking	6
2.0 Installation & Operation	6
3.0 Maintenance & Inspection	7
Figure 6 – maintenance locations	7
3.0 Maintenance & Inspection	8
Figure 7 – maintenance frequency chart	8
4.0 Repair	9
Figure 8 – critical area map	9
5.0 Technical drawings	10
6.0 Replacement parts	11
7.0 Wear data	12
8.0 Reception, storage, transport, decommissioning	13
Certificate of warranty & guarantee of quality	14
Manufacture Information & Revision History	15

"SJ" SERIES ELEVATOR

SAFETY INSTRUCTIONS

The most important safety device for this tool is **YOU**. Your good judgment is the best protection against injury.

⚠ WARNING



To reduce the risk of injury, everyone using, installing, performing maintenance, changing accessories on, or working near this tool must read and understand these instructions before performing any such task.

Operating Hazards

⚠WARNING: Do not overload the elevator. Overloading the recommended rating could cause series injury or death.

⚠WARNING: Secure the Latch Lock Pin in its proper position. Failure to secure the pin when picking up or laying down pipe could cause serious injury or death. See Figure 4.

⚠WARNING: Always ensure that the elevator and bore code are correct for the tubular it is to be used on. Failure to use the proper elevator and bore code could result in injury or death.

⚠WARNING: Always ensure that the tool joint or collar O.D. of the pipe is correct. Failure to maintain adequate contact area could result in injury or death.

⚠WARNING: To prevent injury or elevator malfunction, inspect the elevator bore, latch, hinge pin, and latch pin regularly for wear. Failure to inspect these parts could cause injury or death.

⚠WARNING: Do not use oversized pipe. Using oversized pipe could make it difficult or impossible to properly latch the elevator.

⚠WARNING: Do not use undersized pipe. Using undersized pipe could cause an inadequate load bearing area and uneven stress distribution. Both of which may result in injury or death.

⚠WARNING: Do not use the elevator if the latch or latch lock pin is malfunctioning. Latch or latch lock pin failure, may result in injury or death.

⚠WARNING: All warning labels attached to the equipment must be observed. The warning labels must be present on the tool. Do not remove the labels. If they are missing, replacing is mandatory.

⚠WARNING: The company operating the tool is responsible for issuing work instructions for safe and proper use of the equipment.

⚠WARNING: The operating company is responsible for verifying that any personnel operating, servicing, inspecting, or otherwise involved with the use of the tool must be properly trained correctly.

⚠WARNING: Never install the safety pin without the elevator being properly latched. If pin is installed before it is completely latched, the elevator will have a partial/false latch and could result in injury or death. See Figure 1-3

Vertical / Non-vertical Lifting

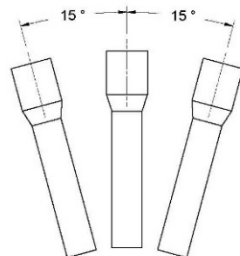

Vertical lifting is considered vertical $\pm 15^\circ$



Non-vertical lifting is considered $\leq 75^\circ$ as max. from horizon.

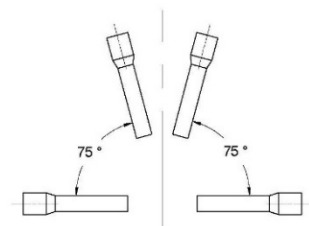

DO NOT DISCARD – GIVE TO USER

Keystone ENERGY TOOLS

"SJ" SERIES ELEVATOR

SAFETY INSTRUCTIONS

The most important safety device for this tool is YOU. Your good judgment is the best protection against injury.

⚠ WARNING



To reduce the risk of injury, everyone using, installing, performing maintenance, changing accessories on, or working near this tool must read and understand these instructions before performing any such task.

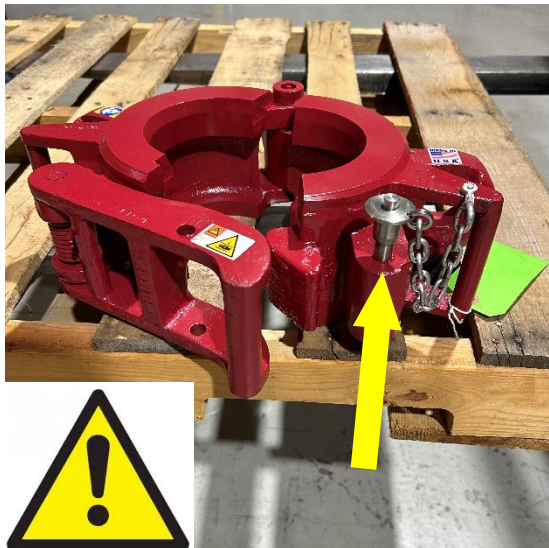

Figure 1: Safety Lock Pin installed incorrectly in the door lug before the elevator is latched

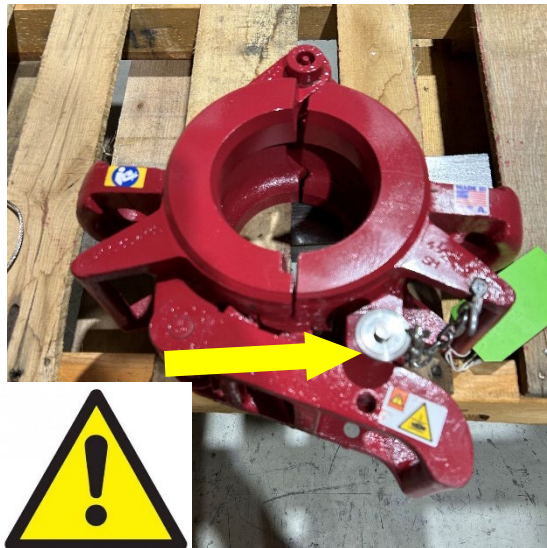

Figure 2: Elevator latched incorrectly with the safety lock pin installed in the door lug

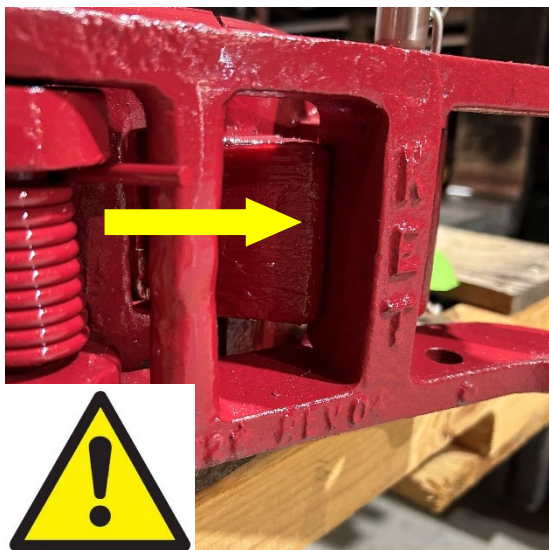

Figure 3: Shows the "Partial Latch" that occurs when the safety latch lock pin is used incorrectly.

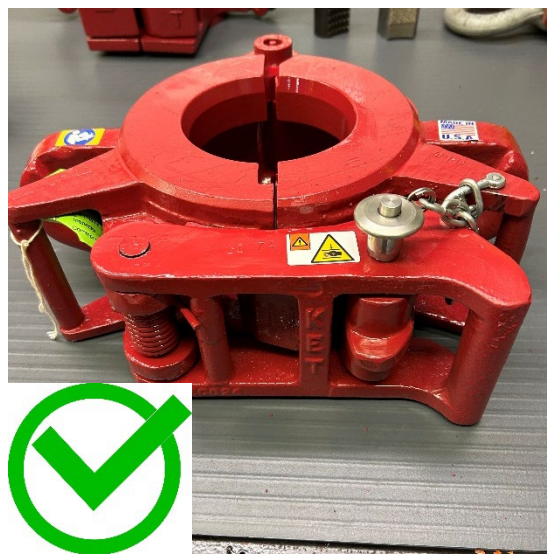

Figure 4: Shows the correct way the elevator should be latched with the safety latch lock pin installed

DO NOT DISCARD – GIVE TO USER **Keystone** ENERGY TOOLS

"SJ" SERIES ELEVATOR

SAFETY INSTRUCTIONS

The most important safety device for this tool is **YOU**. Your good judgment is the best protection against injury.

⚠ WARNING



To reduce the risk of injury, everyone using, installing, performing maintenance, changing accessories on, or working near this tool must read and understand these instructions before performing any such task.

Workplace Hazards

⚠WARNING: keep hands fingers clear of the elevator bore when installing the elevator around the pipe.

⚠WARNING: Always use the proper tools and wear eye, head, hand, and foot protection when servicing this elevator.

⚠WARNING: Maintain a balanced body position and secure footing.

⚠WARNING: For professional use only.

Maintenance Hazards

⚠WARNING: Use only Keystone Energy Tool components on equipment. Failure to do so may affect the correct functioning of the tool and may cause injury or death.

⚠WARNING: KET equipment is made of cast alloy heat treated steel and should never be welded on in the field. Improper welding can cause cracks or brittleness in the castings which could result in drastic weakening or failure of the equipment. Any welding or machining must be performed by an authorized KET or API certified repair center.

⚠WARNING: Improper welding and/or re-machining of cast alloy heat treated steel can cause personnel injury, property damage, or death.



Read Operation manual before use.



Pay attention: do not place your hands between moving parts.



DO NOT lift from this area.



Be careful when lifting from these areas.

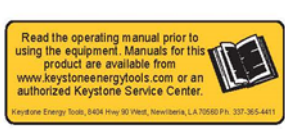

WARNING: Only Keystone parts should be used. Elevators are cast alloy heat treated steel and should not be welded in the field. Improper welding can cause cracks and brittleness in heat affected areas which can result in serious weakening of the part and possible failure. Repairs involving welding or machining should be performed only by an authorized Keystone repair facility. Using an elevator that has been improperly welded can cause failure which may result in serious bodily injury or property damage.

Keystone
ENERGY TOOLS

DO NOT DISCARD – GIVE TO USER **Keystone** ENERGY TOOLS

1.0 Introduction

This manual contains operation and maintenance instructions for the Keystone Energy Tools (KET) “SJ” series single joint elevator and provides instruction for its proper field use, disassembly and repair; including a complete parts breakdown.

(KET) “SJ” elevators are designed to replace rope slings for hoisting collar type and bottleneck pipe into position when adding to a string. SJ elevators allow the crew to handle pipe properly, thus avoiding pipe thread damage and reduces the chances of accidents/injuries.

The SJ series pick up elevator has a simple, reliable latch that closes simultaneously when the elevator is closed. To ensure the Latch does not open, the Latch Lock Pin must be used. The size range of the SJ series elevator is as illustrated in the table provided. (See Figure 5)

If the safety latch lock pin is installed correctly, then the SJ series elevator can perform non-vertical lifts (picking up of horizontal pipe). Failure to not install the safety latch lock pin correctly may result in injury or death. (See Figure 4)

If the Safety Latch Lock Pin is inserted into the Latch or Door Lug before closing the Elevator, the Safety Latch Lock Pin will prevent the latch from fully engaging the Latch Lug on the door resulting in a partial/false latch. (See Figure 1-3)

Model	Tons	Range
SJ-30	7.5/10/12	4" – 5 7/8"
SJ-40	7.5/10	5 1/2" – 8 5/8"
SJ-50	7.5/10	9 5/8" – 10 3/4"
SJ-60	7.5/10	11 3/4" – 14"
SJ-65	7.5/10	18" - 22"

Figure 5

NOTE: WARNING labels have been installed at critical areas on the tool. Familiarize yourself with their message and locations before proceeding to operate equipment.

See Safety Instructions Page 4

⚠WARNING: During use, the elevator should never be run into the tool joints or couplings inducing any type of shock load into the equipment. Shock loads are an impact-type force applied over a short instant of time. In shock loading, the energy of the applied force is ultimately absorbed, or transferred, to the elevator designed to resist the force. The application of shock loads to an elevator can cause shock/fatigue stress loading potentially resulting in premature stress/fatigue failure.



CE Marking

The tool complies with the Machinery Directive 98/37/EC and 2006/42/EC

This operating manual is a part of the technical documentation for the product.

The EC Declaration of Conformity is delivered together with the product. Keep these instructions and the associated documents for later use.

NOTE: Use on pipe weighing 7.5- Short Tons (6.8 metric tons) or less.

2.0 Operation

As with any manual operated elevator, the SJ is easily installed by the user. Perform the actions prescribed below after the elevator is hoisted to the rig floor and properly positioned.

- ▶ Remove the bolt from the shackle on the swivel suspension assembly.
- ▶ Attach the shackle over the lifting eye on the elevator then replace the bolt to the shackle.
- ▶ Repeat the process for the opposite lifting eye. To remove the elevator, simply reverse the process.

The operation of the SJ elevator is straightforward. The door is opened by removing the Safety Latch Pin and pulling outward on the Latch Lock. When the elevator is properly closed around the pipe, install the Latch Lock Pin Retainer.



3.0 Maintenance & Inspection

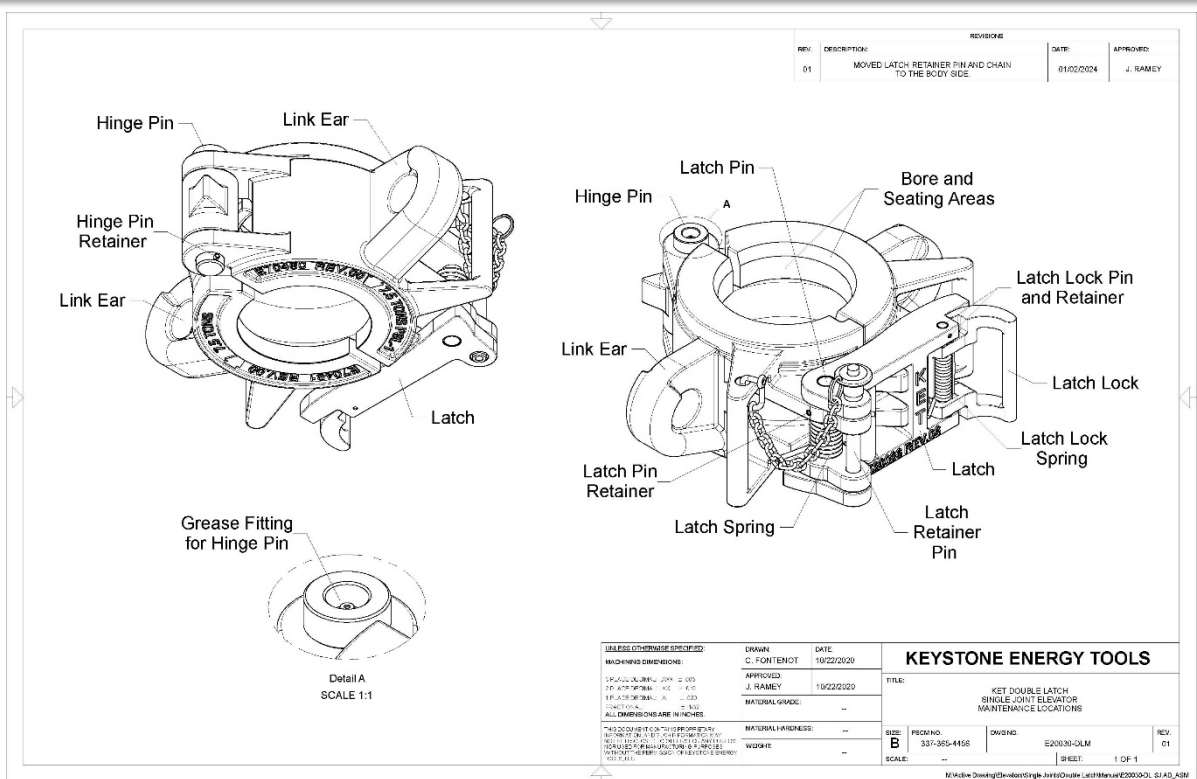

Figure 6

To ensure optimum performance, perform the below-listed weekly checks.

- Check for worn Hinge Pin and Latch Pin and their mating parts. These, if worn, may hinder proper opening and closing of the door and latch.
- Check the Latch Lock Pin assembly for worn or damaged parts. (e.g. Safety Latch Pin)
- Check for proper Latch Spring performance.
- Check for proper operation of Latch Stop mechanism. Latch should not stop against the door when engaged.
- Check springs for damage, deformation and lack of tension.

Lubricate the elevator regularly during usage and storage to prevent corrosion. Use an extreme pressure, multi-purpose, lithium base grease of No. 1 or No. 2 consistency or a lubricant that meets MIL-SPEC-A907E.

3.0 Maintenance & Inspection

The owner/user of the equipment should develop schedules of inspection based upon experience, manufactures recommendations, and one or more of the following factors:

- ▶ Environment
- ▶ Load Cycles
- ▶ Regulatory requirements
- ▶ Operating time
- ▶ Testing
- ▶ Repairs
- ▶ Remanufacture

“Proof Load Test” shall be performed only once following manufacture or remanufacture. This is by applying a load equal to 1.5 times the rated load for a period no less than 5 min. A proof load test shall be followed by surface NDT no earlier than 24 hrs. after proof of testing.

“Performance Load Test” is recommended after 365 days of accumulative use. This test is to verify the function of the equipment to perform under the conditions or in conjunction with other equipment. The Performance Test may consist of loads up to, but not exceeding, the rated load of the equipment.

Lubricate the elevator regularly during usage and storage to prevent corrosion. Use an extreme pressure, multi-purpose, lithium base grease of No. 1 or No. 2 consistency or a lubricant that meets MIL-SPEC-A907E.

****When greasing of pins make sure the pump grease until it comes out of both ends.****

Maintain elevator as prescribed in the below periodic Actions/Examinations. (See Figure 7)

Reference API 8B Recommended Practice

Category III: Every 6 months the equipment should include NDT of critical areas and may involve some disassembly to access specific components and to identify wear that exceeds the allowable wear tolerances.

Category IV: Every 12 months the equipment **shall** be disassembled to permit the necessary full NDT inspection of all primary load carrying components per ASTM E-709 (see figure 5). Including inspection for excessive wear, cracks, flaws , and deformations.

If any repair work is required, the equipment shall be sent into a Keystone Energy Tool facility for evaluation.

Tool Maintenance		
ACTION	FREQUENCY	FIG.
Grease Hinge Pin	Daily	6
Lubricate Latch Pin		6
Lubricate Latch Lock Bolt		6
Grease Underside of Lifting Eye		6
Grease Bore and Seating Surface		6
MPI Category III	Every 6 Months	8
MPI Category IV	Every 12 Months	8
Performance Load Test	Every 365 Days “See left”	-

Figure 7

4.0 Repair & Critical Areas

The SJ series elevator requires minimum attention. To Remove and Replace the Hinge Pin, Hinge Pin Retainer Pin, Latch Pin, and Latch Lock Pin assembly described below.

- To remove the Hinge Pin, first remove the Hinge Pin Retainer Pin. Drive out the Hinge pin from the bottom of the elevator. Replace the Hinge Pin and Hinge Pin Retainer Pin.
- To remove the Latch Pin, first remove the Latch Pin Retainer Pin. Drive out the Latch Pin from the bottom of the elevator. Replace the Latch Pin, Latch Pin Spring, and Latch Retainer Pin.
- To remove Latch Lock Pin Assembly, remove the cable end ring from the split ring on the elevator door handle.

We have identified those areas considered critical to tool performance and functionality. These should be examined for repair or replacement. (See Figure 8)

Bodies, doors and latches are specifically matched by trained Keystone Energy Tools professionals. For this reason, a body, door or latch from one elevator should never be exchanged with a body, door, or latch from another elevator.

Illustrated below are the critical and non-critical areas associated with the subject tool. Critical areas are identified by the shaded areas. All non-shaded areas are considered non-critical.

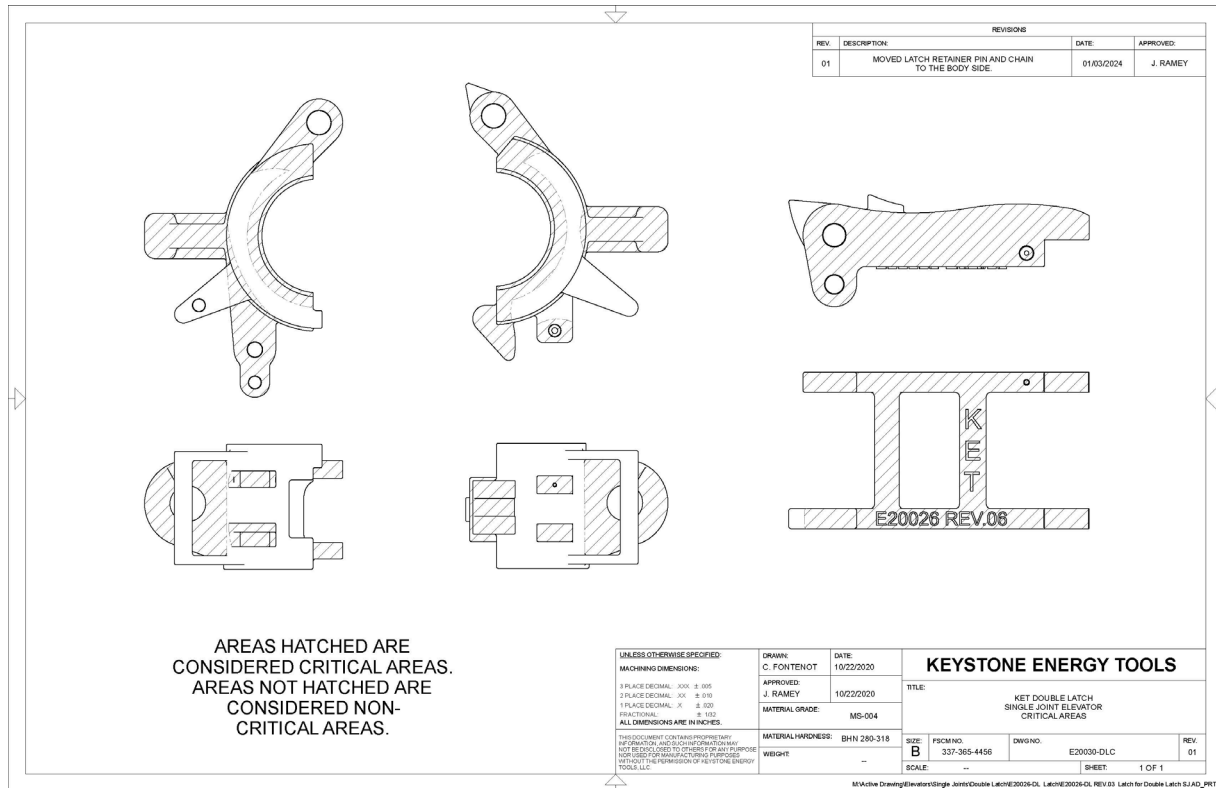
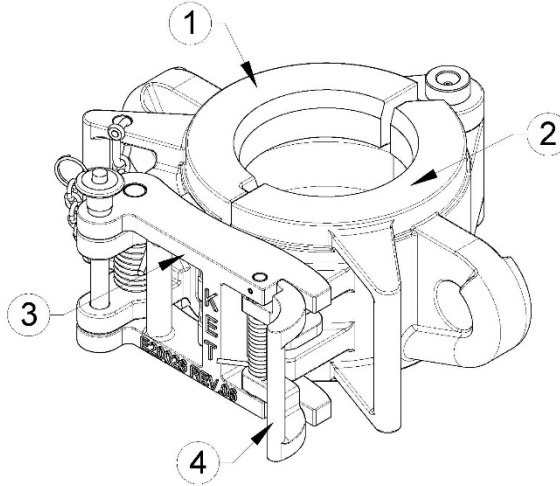

Figure 8

5.0 Elevator Technical Drawings

1. ELEVATOR BODY
2. ELEVATOR DOOR
3. LATCH
4. LATCH LOCK



REV.		DESCRIPTION	DATE	APPROVED
0		INITIAL RELEASE.	10/22/2020	J. RAMEY

UNLESS OTHERWISE SPECIFIED:		DRAWN:	DATE:	KEYSTONE ENERGY TOOLS	
MACHINING DIMENSIONS:		C. FONTENOT	10/22/2020	TITLE:	
1X UNLESS OTHERWISE SPECIFIED:		APPROVED:	10/22/2020	KET DOUBLE LATCH	
2X UNLESS OTHERWISE SPECIFIED:		J. RAMEY		SINGLE JOINT ELEVATOR	
3X UNLESS OTHERWISE SPECIFIED:		MATERIAL GRADE:	--	MAIN COMPONENTS	
4X UNLESS OTHERWISE SPECIFIED:		MATERIAL HARDNESS:	--	SIZE:	REV:
5X UNLESS OTHERWISE SPECIFIED:		WEIGHT:	--	B	0
6X UNLESS OTHERWISE SPECIFIED:				PCOM NO:	DWG NO:
7X UNLESS OTHERWISE SPECIFIED:				337-365-4456	E2000-DIA
8X UNLESS OTHERWISE SPECIFIED:				SCALE:	SHEET:
9X UNLESS OTHERWISE SPECIFIED:				1:2	1 OF 1

0	INITIAL RELEASE.	06/15/2020	J. RAMEY
---	------------------	------------	----------

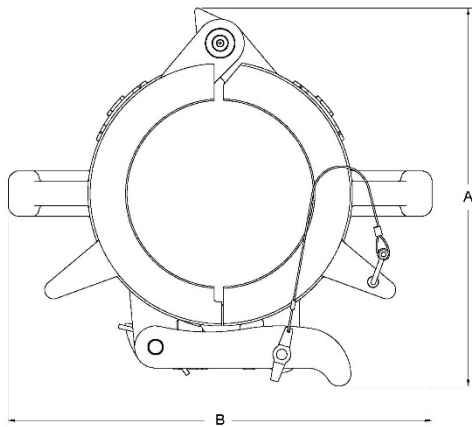

Model	Flange	Dimension A	Dimension B	Dimension C	Dimension D	Dimension L
L2003D	4" - 5.875"	15.4"	14.5"	5.5"	5.25"	5.4"
L2004D	5.5" - 8.625"	15.71"	17.63"	7"	5.25"	5.4"
E2005D	9.625" - 10.75"	17.53"	19.5"	7.88"	5.25"	5.4"
E2006D	11.75" - 14"	20.04"	22.75"	9.56"	5.25"	5.4"
E2006S	18.625" - 20"	28.32"	29.63"	12.94"	5.25"	5.4"

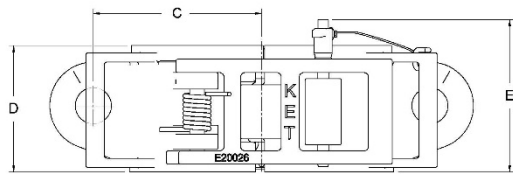

UNLESS OTHERWISE SPECIFIED:		DRAWN:	DATE:	KEYSTONE ENERGY TOOLS	
MACHINING DIMENSIONS:		C. FONTENOT	09/15/2020	TITLE:	
1X UNLESS OTHERWISE SPECIFIED:		APPROVED:	09/15/2020	KET SINGLE JOINT ELEVATOR	
2X UNLESS OTHERWISE SPECIFIED:		J. RAMEY		APPROXIMATE SIZE DIMENSIONS	
3X UNLESS OTHERWISE SPECIFIED:		MATERIAL GRADE:	--	SIZE:	REV:
4X UNLESS OTHERWISE SPECIFIED:		MATERIAL HARDNESS:	--	B	0
5X UNLESS OTHERWISE SPECIFIED:		WEIGHT:	--	PCOM NO:	DWG NO:
6X UNLESS OTHERWISE SPECIFIED:				337-365-4456	E2000-D
7X UNLESS OTHERWISE SPECIFIED:				SCALE:	SHEET:
8X UNLESS OTHERWISE SPECIFIED:				--	1 OF 1

6.0 Replacement Parts

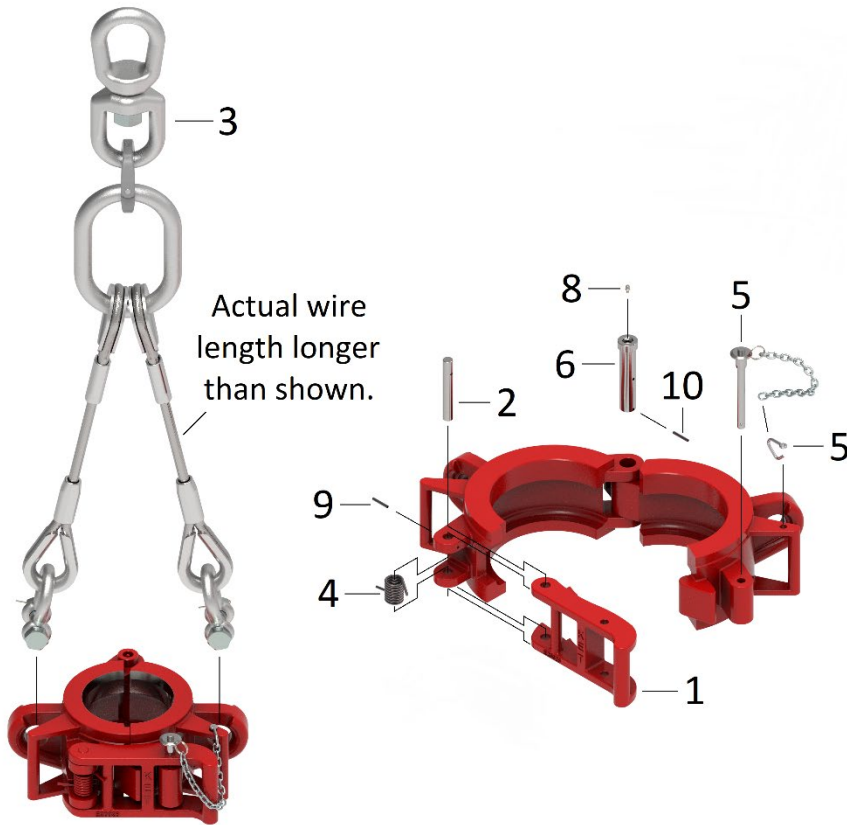

ITEM	QTY	PART No.	DESCRIPTION
1	1	E20026	LATCH
2	1	E39-050	LATCH PIN
3	1	E34568	SJ SWIVEL SUSPENSION ASSEMBLY
4	1	E7829-1	LATCH SPRING
5	1	E39-051-8	LATCH LOCK RETAINER PIN ASSEMBLY
6	1	E39-052	HINGE PIN *COMES WITH GREASE ZERT*
7	1	N/A	N/A
8	1	E316-TI	TAP IN GREASE FITTING
9	1	E316RP	LATCH PIN RETAINER (SAME AS HINGE)
10	1	E316RP	HINGE PIN REATAINER (SAME AS LATCH)

⚠WARNING: Use only Keystone Energy Tool components on equipment. Failure to do so may affect the correct functioning of the tool and may cause injury or death.

7.0 Wear Data for Single Joint Elevators

SIZE	2 3/8" - 16"
RATED CAPACITY	7.5 TONS

STANDARD PINS

HINGE PIN PART #	E39-052
TOTAL CLEARANCE (H)	0.025
HINGE PIN MIN. DIA. NEW	.992
BORE DIA. MAX. NEW	1.010
BORE DIA. MAX. WORN	1.015

LATCH PIN PART #	E39-050
TOTAL CLEARANCE (L)	0.025
LATCH PIN MIN. DIA.	0.620
BORE DIA. MAX. NEW	0.637
BORE DIA. MAX. WORN	0.645

1/16" OVERSIZE PINS

HINGE PIN PART #	E39-052-R
TOTAL CLEARANCE (H)	0.025
HINGE PIN MIN. DIA.	1.059
BORE DIA. MAX. NEW	1.064
BORE DIA. MAX. WORN	1.078

LATCH PIN PART #	N/A
TOTAL CLEARANCE (L)	N/A
LATCH PIN MIN. DIA. NEW	N/A
BORE DIA. MAX. NEW	N/A
BORE DIA. MAX. WORN	N/A

1/8" OVERSIZE PINS

HINGE PIN PART #	N/A
TOTAL CLEARANCE (H)	N/A
HINGE PIN MIN. DIA.	N/A
BORE DIA. MAX. NEW	N/A
BORE DIA. MAX. WORN	N/A

LATCH PIN PART #	N/A
TOTAL CLEARANCE (L)	N/A
LATCH PIN MIN. DIA. NEW	N/A
BORE DIA. MAX. NEW	N/A
BORE DIA. MAX. WORN	N/A

SAFETY LATCH LOCK PIN

DIMENSION (A)MAX	0.530
DIMENSION (C)MIN	3.938"

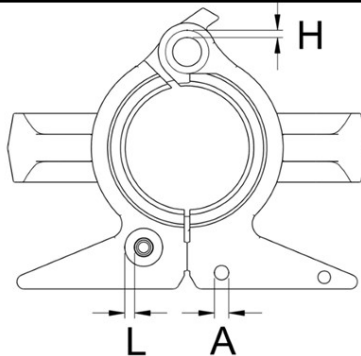

LIFTING EARS

RADIUS - R	0.625
DIMENSION (D) MIN	0.750

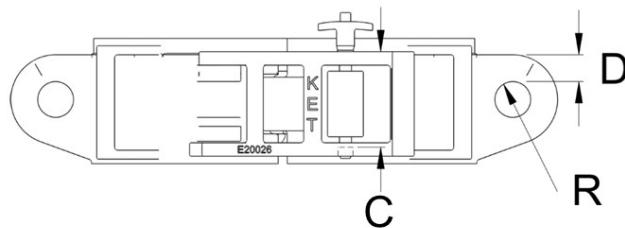

8.0 Reception, Storage, Transport & Decommissioning

Reception

Check the tool immediately after reception and re-preserve the tool as required (try to have this completed within 1 month).

Any exposed or non painted metal surfaces should be coated with a rust preventative to prevent any corrosion build up.

Storage

The tool should be stored or palletized in a clean and dry place to avoid all environmental elements. It is recommended to store in an indoor environment of 60 – 70 Deg F with max humidity of 80%. If the tool is to be stored outdoor, then a cargo container would be appropriate to ensure the tool is not exposed to weather conditions.

Preserve the tool by greasing all areas defined in the maintenance requirements per the manual.

During storage, the tool shall still be inspected annually per inspection requirements in the user's manual.

Transport

When lifting the tool do so only by using its lifting ears only. The best way of transporting the tool is in its original palletized state. Ensure the tool is banded down accordingly to prevent the possibility of potential dropped objects and broken shipments.

Decommissioning

The tool may contain grease, steel, rubbers, plastic, stainless steel, mild steel and several assembled components with undefined consistency or mixtures. The tool can be contaminated with drilling fluids, hydraulic fluids and preservatives. After the tool is decommissioned, it is recommended to disassemble the tool in a place where waste fluids can be contained and properly disposed of.

⚠WARNING: any fluids, mud, or grease are potentially unsafe when in contact with the skin. Always wear gloves and safety goggles when disassembling the tool.

1. Clean the tool with a steam cleaner.
2. It is recommended to disassemble the tool in a place where drainage for waste fluids is possible.

CERTIFICATE OF WARRANTY AND GUARANTEE OF QUALITY

KET warrants all materials and products manufactured to be free from defects in material and workmanship, under normal use and service, when installed, used, and serviced in the manner provided and intended by the seller for a period of twelve (12) months after delivery. Seller's obligation under this warranty is expressly limited to repair or replacement, at its option, of any materials or products, returned to the seller's plant in New Iberia, Louisiana and which are determined by the seller to be defective. All freight charges for return and reshipment shall be paid by the customer. A new warranty period shall not be established for repaired or replaced material or products; such items shall remain under warranty only for the remainder of the warranty period on the original materials or products. This is the sole warranty of the seller and no other warranty is either expressed or implied, in fact or by law, including any warranty at to the merchantability or fitness for a particular use or purpose.

In case of goods or parts not wholly of seller's manufacture, seller shall make available to the customer whatever warranty or guarantee is extended to seller for such goods or parts by the supplier or manufacturer thereof.

Seller will not assume responsibility or liability for any repairs, rebuilding, welding or heat treating done to its material or products outside of seller's plant, such work shall void all warranties. All parts used in the manufacture and /or final assembly of seller's materials or products are necessary for both safety and operational performance. Omission of any part or failure to replace any worn part may result in the malfunction and a consequent safety hazard for which seller disclaims any responsibility or liability for injuries or damage as a result thereof.

Buyer's sole and only remedy in regard to any defective materials or products shall be the repair or replacement thereof as herein provided, and seller shall not be liable for any consequential, special, incidental or punitive damages resulting from or caused by any defective materials, products or supplies.



For more information, please contact us at:

Keystone Energy Tools
3711 Melancon Rd.
Broussard, LA 70518

www.k-e-t.com

Office: 1-337-365-4411
Fax: 1-337-365-4456

Revision History			
Rev.	Date	Changes	By
03	05/26/2021	Format change/rev history added	Cody H.
04	10/18/2021	Added Category III & IV definitions	Cody H.
05	05/02/2022	Update Wear Data	Cody H.
06	07/13/2022	Update Wear Data	Cody H.
07	07/19/2022	Updated address	Cody H.
08	11/10/2022	Updated Introduction & added warning to warning page concerning use of safety latch lock pin	Cody H.
09	02/06/2023	Added page 4 safety instructions & figures of latching the elevator properly/incorrectly	Cody H.
10	08/25/2023	Added new ratings in tonnage	Cody H.
11	01/18/2024	Updated drawings and renderings (new latch	Cody H.
12	02/07/2024	Updated wear data	Cody H.
13	04/04/2024	Added warning ab out shock loading	Cody H.