



Keystone
ENERGY TOOLS

THE TMA 100 TON SQUARE SHOULDER ELEVATOR OPERATING PROCEDURE MANUAL

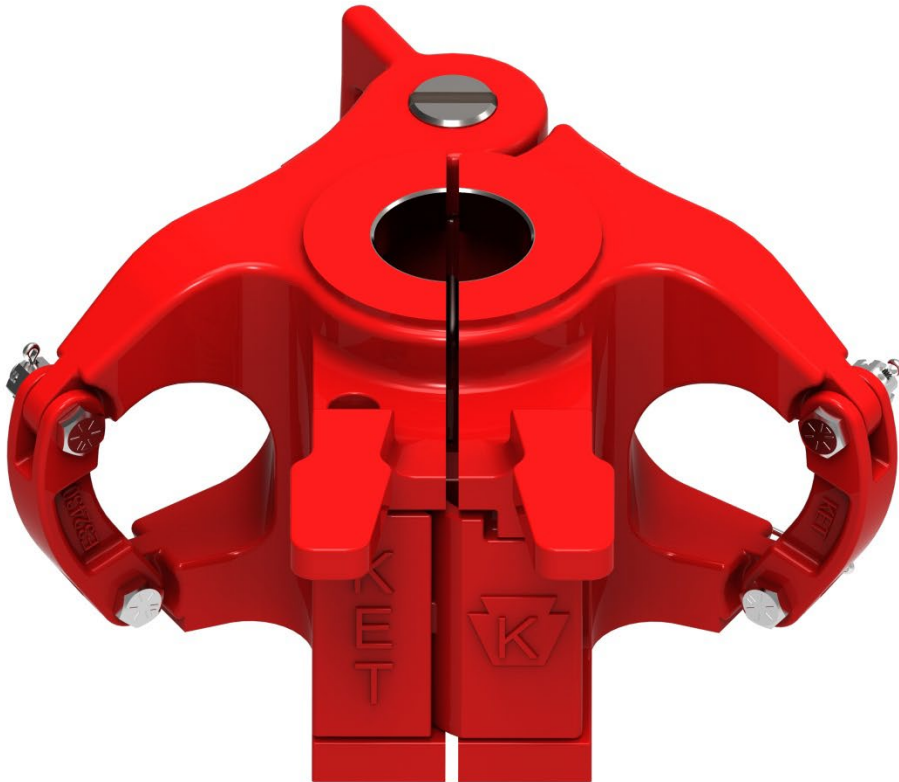

Table of Contents

Table of contents	2
Safety instructions	3
vertical vs horizontal lifts	3
Safety instructions	4
1.0 Introduction	5
Figure 2 – TMA model chart	5
CE Marking	5
2.0 Installation & Operation	6
3.0 Maintenance & Inspection	7
Figure 2 – maintenance locations	7
3.0 Maintenance & Inspection	8
Figure 3 – maintenance frequency chart	8
4.0 Repair	9
Figure 4 – critical area map	10
5.0 Technical drawings	11
6.0 Replacement parts	12
7.0 Wear data	13
8.0 Reception, storage, transport, decommissioning	14
Certificate of warranty & guarantee of quality	15
Manufacture Information & Revision History	16

"TMA" SERIES ELEVATOR

SAFETY INSTRUCTIONS

The most important safety device for this tool is **YOU**. Your good judgment is the best protection against injury.

⚠ WARNING



To reduce the risk of injury, everyone using, installing, performing maintenance, changing accessories on, or working near this tool must read and understand these instructions before performing any such task.

Operating Hazards

⚠WARNING: Do not overload the elevator. Overloading the recommended rating could cause series injury or death.

⚠WARNING: Check the latch for proper engagement. A malfunctioning latch could cause the elevator to unexpectedly unlatch or not latch at all resulting in injury or death.

⚠WARNING: Always ensure that the elevator and bore code are correct for the tubular it is to be used on. Failure to use the proper elevator and bore code could result in injury or death.

⚠WARNING: To prevent injury or elevator malfunction, inspect the elevator bore, latch, hinge pin, and latch pin regularly for wear. Failure to inspect these parts could cause injury or death.

⚠WARNING: Do not use oversized pipe. Using oversized pipe could make it difficult or impossible to properly latch the elevator.

⚠WARNING: Do not use undersized pipe. Using undersized pipe could cause an inadequate load bearing area and uneven stress distribution. Both of which may result in injury or death.

⚠WARNING: Do not use the elevator if the latch or latch lock is malfunctioning. Latch or latch lock failure, may result in injury or death.

⚠WARNING: All warning labels attached to the equipment must be observed. The warning labels must be present on the tool. Do not remove the labels. If they are missing, replacing is mandatory.

⚠WARNING: The company operating the tool is responsible for issuing work instructions for safe and proper use of the equipment.

⚠WARNING: The operating company is responsible for verifying that any personnel operating, servicing, inspecting, or otherwise involved with the use of the tool must be properly trained correctly.

⚠WARNING: The lifting of vertical pipe is to be performed carefully and must be monitored. The picking up of non-horizontal pipe is dangerous and not permitted.

Vertical / Non-vertical Lifting

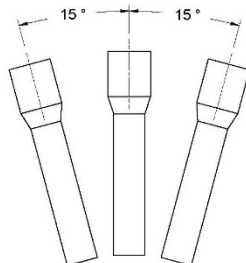

Vertical lifting is considered vertical $\pm 15^\circ$



Non-vertical lifting is considered $\leq 75^\circ$ as max. from horizon.

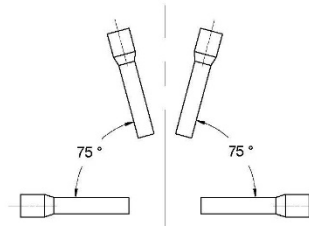

Figure 1

DO NOT DISCARD – GIVE TO USER

Keystone ENERGY TOOLS

"TMA" SERIES ELEVATOR

SAFETY INSTRUCTIONS

The most important safety device for this tool is **YOU**. Your good judgment is the best protection against injury.

⚠ WARNING



To reduce the risk of injury, everyone using, installing, performing maintenance, changing accessories on, or working near this tool must read and understand these instructions before performing any such task.

Operating Hazards

⚠WARNING: Do not overload the elevator. Overloading the recommended rating could cause series injury or death.

⚠WARNING: Check the latch for proper engagement. A malfunctioning latch could cause the elevator to unexpectedly unlatch or not latch at all resulting in injury or death.

⚠WARNING: Always ensure that the elevator and bore code are correct for the tubular it is to be used on. Failure to use the proper elevator and bore code could result in injury or death.

⚠WARNING: To prevent injury or elevator malfunction, inspect the elevator bore, latch, hinge pin, and latch pin regularly for wear. Failure to inspect these parts could cause injury or death.

⚠WARNING: Do not use oversized pipe. Using oversized pipe could make it difficult or impossible to properly latch the elevator.

⚠WARNING: Do not use undersized pipe. Using undersized pipe could cause an inadequate load bearing area and uneven stress distribution. Both of which may result in injury or death.

⚠WARNING: Do not use the elevator if the latch or latch lock is malfunctioning. Latch or latch lock failure, may result in injury or death.

⚠WARNING: All warning labels attached to the equipment must be observed. The warning labels must be present on the tool. Do not remove the labels. If they are missing, replacing is mandatory.

⚠WARNING: The company operating the tool is responsible for issuing work instructions for safe and proper use of the equipment.

⚠WARNING: The operating company is responsible for verifying that any personnel operating, servicing, inspecting, or otherwise involved with the use of the tool must be properly trained correctly.

⚠WARNING: The lifting of vertical pipe is to be performed carefully and must be monitored. The picking up of non-horizontal pipe is dangerous and not permitted.

Vertical / Non-vertical Lifting

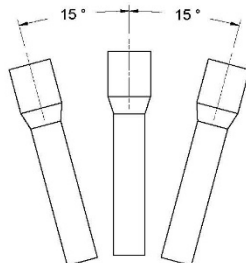

Vertical lifting is considered vertical $\pm 15^\circ$



Non-vertical lifting is considered $\leq 75^\circ$ as max. from horizon.

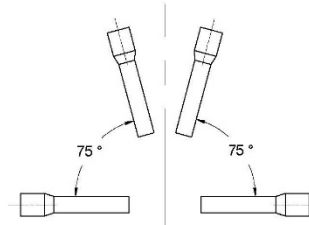

Figure 1

DO NOT DISCARD – GIVE TO USER

Keystone ENERGY TOOLS

1.0 Introduction

This manual contains operation and maintenance instructions for the Keystone Energy Tools (KET) “TMA” series, Square Shoulder Center Latch elevators for handling Tubing and Casing with assembly drawings and complete parts breakdown. It provides a guide for proper field use, disassembling and repair.

(KET) “TMA” series elevators are designed to be used with tubing and casing. They are balanced making them easy to handle as well as easy to latch on or take off at any point below the upset of the pipe. “TMA” series elevators are made of high alloy-heat treated steel and designed to meet or exceed API specifications.

The “TMA” series elevator includes safety features such as guarded operating handles to help prevent injury to operators and an extra handle at the rear of the elevator for easier, safer operation. The “TMA” series elevators incorporate a latch and safety latch lock combination. The size range of the “TMA” series elevator is as illustrated in the table provided.

(See Figure 1)

Model	Tons	Range
TMA	100	2-3/8” - 5”

Figure 1

NOTE: WARNING labels have been installed at critical areas on the tool. Familiarize yourself with their message and locations before proceeding to operate equipment.

See Safety Instructions Page 4

⚠WARNING: During use, the elevator should never be run into the tool joints or couplings inducing any type of shock load into the equipment. Shock loads are an impact-type force applied over a short instant of time. In shock loading, the energy of the applied force is ultimately absorbed, or transferred, to the elevator designed to resist the force. The application of shock loads to an elevator can cause shock/fatigue stress loading potentially resulting in premature stress/fatigue failure.



CE Marking

The tool complies with the Machinery Directive 98/37/EC and 2006/42/EC

This operating manual is a part of the technical documentation for the product.

The EC Declaration of Conformity is delivered together with the product. Keep these instructions and the associated documents for later use.

2.0 Operation

As with any manual operated elevator, the “TMA” series is easily installed by the user. Perform the actions described below after the elevator is hoisted to the rig floor and properly positioned.

- Remove cotter pins and nuts from the link block bolts and then remove the bolts from the elevator.
- Lift the bottom of the link blocks and hook the small end of the links through the link blocks and link arms.
- Lower the link blocks and re-install the link block bolts, nuts and cotter pins.

The operation of the “TMA” series elevator is straightforward. The door is opened by gripping the latch lock and pulling outward. This automatically releases the latch and latch lock assembly so the elevator can be positioned on the pipe. When the elevator is properly closed around the pipe, the latch locks automatically.

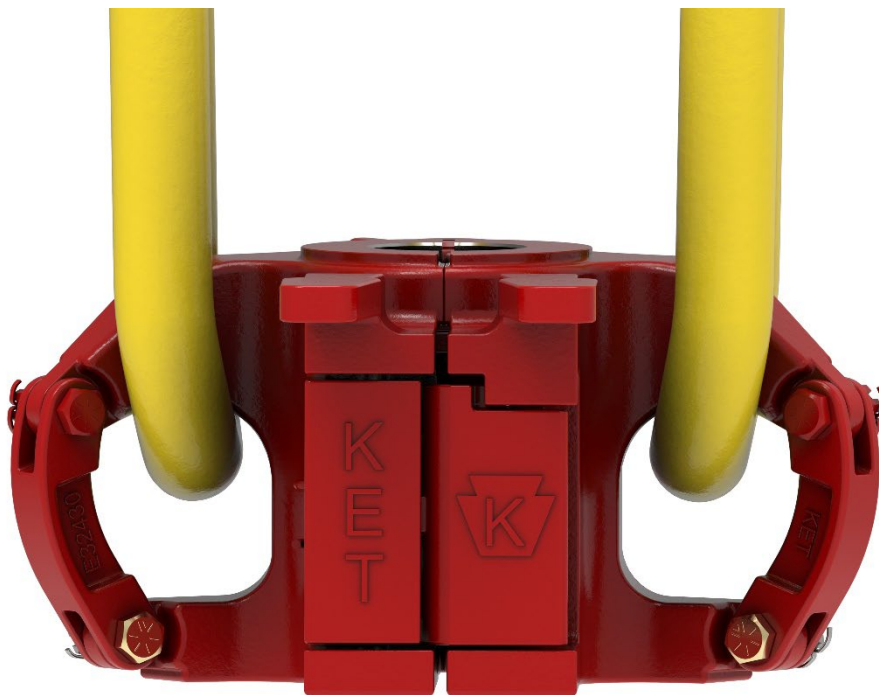

3.0 Maintenance & Inspection

Below is a diagram of each elevator maintenance location located on the TMA elevator. See figure 2.

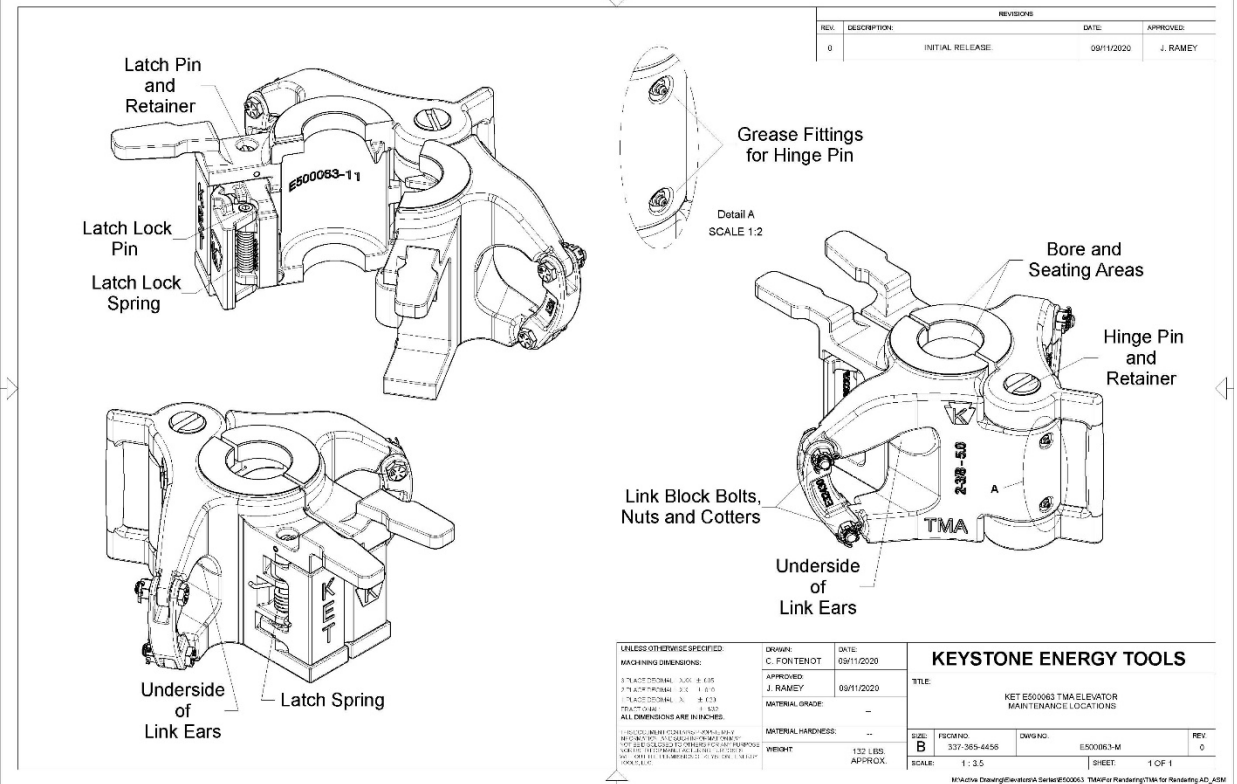

Figure 2

To ensure optimum performance, perform the below-listed daily checks.

- Visually inspects for cracks, loose fits or connections, elongation of parts, and other signs of wear, corrosion or overloading.
- Loose or missing components, deterioration, proper lubrication, and adjustment.
- Check for worn hinge pin, latch pin and latch lock pin. These may inhibit proper closing of the door and latch lock engagement.
- Check for proper operation of Latch Stop mechanism. Latch should not stop against the door when closed but have no more than 1/4" of standoff from the door. Check springs for damage, deformation, and lack of tension.
- Check link block bolts for nuts and cotter pins.

3.0 Maintenance & Inspection

The owner/user of the equipment should develop schedules of inspection based upon experience, manufactures recommendations, and one or more of the following factors:

- ▶ Environment
- ▶ Load Cycles
- ▶ Regulatory requirements
- ▶ Operating time
- ▶ Testing
- ▶ Repairs
- ▶ Remanufacture

Proof Load Test shall be performed only once following manufacture or remanufacture. This is by applying a load equal to 1.5 times the rated load for a period no less than 5 min. A proof load test shall be followed by surface NDT no earlier than 24 hrs. after proof of testing.

Lubricate the elevator regularly during usage and storage to prevent corrosion. Use an extreme pressure, multi-purpose, lithium base grease of No. 1 or No. 2 consistency or a lubricant that meets MIL-SPEC-A907E.

When greasing of pins make sure the pump grease until it comes out of both ends.

Maintain elevator as prescribed in the below periodic Actions/Examinations. (See Figure 3)

Figure 3

Reference API 8B Recommended Practice

Every 12 months the equipment **shall** be disassembled to permit the necessary full NDT inspection of all primary load carrying components per ASTM E-709 (see figure 5). Including inspection for excessive wear, cracks, flaws , and deformations.

If any repair work is required, the equipment shall be sent into a Keystone Energy Tool facility for evaluation.

“Performance Load Test” is recommended after 365 days of accumulative use. This test is to verify the function of the equipment to perform under the conditions or in conjunction with other equipment. The Performance Test may consist of loads up to, but not exceeding, the rated load of the equipment.

Tool Maintenance		
ACTION	FREQUENCY	FIG.
Grease Hinge Pin	Daily	6
Lubricate Latch Pin		6
Lubricate Latch Lock Bolt		6
Grease Underside of Lifting Eye		6
Grease Bore and Seating Surface		6
MPI Category III	Every 6 Months	8
MPI Category IV	Every 12 Months	8
Performance Load Test	Every 365 Days “See left”	-

4.0 Repair

DISASSEMBLY PROCEDURE

- Remove the latch lock assembly and latch spring by driving or pressing out the lock bar and driving out the latch pin from the bottom of the elevator.
- Remove the latch lock from the latch by removing the Teflon nut and drive or press out the bolt.
- Remove the hinge pin by driving it out from the bottom of the elevator, shearing the lock bar in the process and remove the latch pin in the same manner. As an alternative method, the lock bar can be drilled in the center, then split by using a chisel and removed. In either case the lock bar must be discarded.
- If either link block is to be replaced, remove the link block bolt and cotter pins.
- If the door lug pin is damaged, drive or press it out from the bottom of the lug.
- Reassemble by reversing the above steps.
- Install new lock bars on hinge and latch pins.
- After assembly, ensure that full spring tension is available to close the latch & lock. The latch spring should contact the spring stop pin which in turn transmits the spring force to the latch.
- Check the latch for proper engagement with the door lug pin by holding the body and door apart (such that the latch contacts the lug on the door) and attempt to pry the latch open. After minimal of the latch the hook on the latch should engage with the door lug pin stopping the travel of the latch.
- Check link block bolts, nuts, and cotter pins.

4.0 Repair

We have identified those areas considered critical to tool performance and functionality. These should be examined for repair or replacement. (See Figure 4)

Bodies, doors and latches are specifically matched by trained Keystone Energy Tools professionals. For this reason, a body, door or latch from one elevator should never be exchanged with a body, door, or latch from another elevator.

Illustrated below are the critical and non-critical areas associated with the subject tool. Critical areas are identified by the shaded areas. All non-shaded areas are considered non-critical.

TMA ELEVATOR CRITICAL AREAS

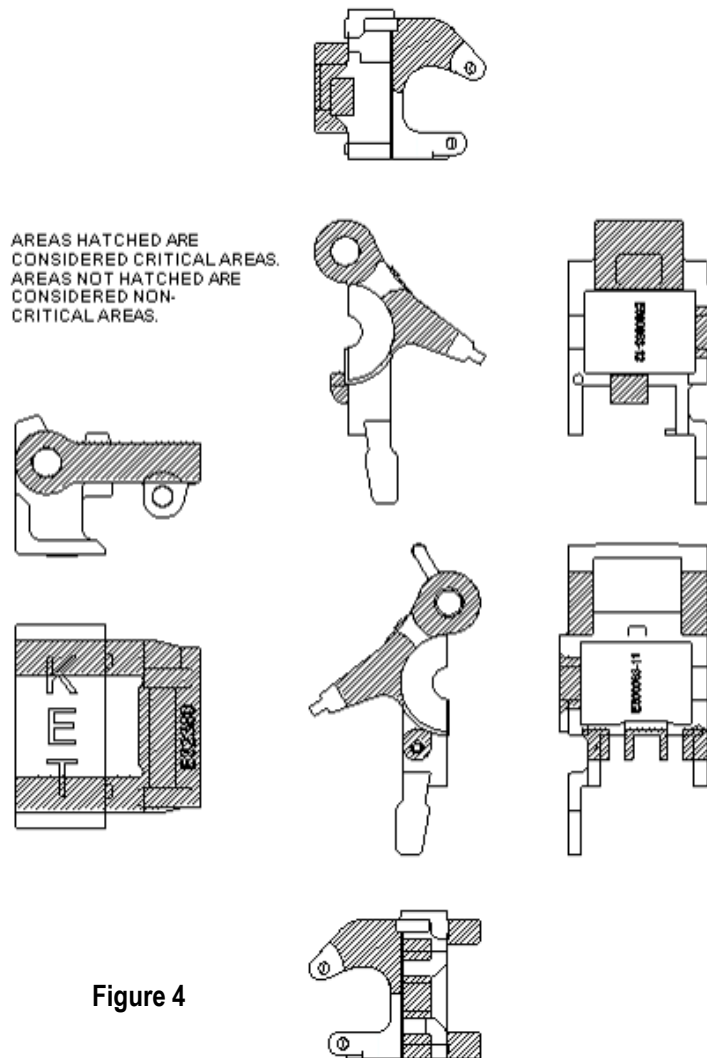

5.0 Elevator Technical Drawings

REVISIONS			
REV.	DESCRIPTION	DATE	APPROVED
0	INITIAL RELEASE	09/11/2020	J. RAMEY

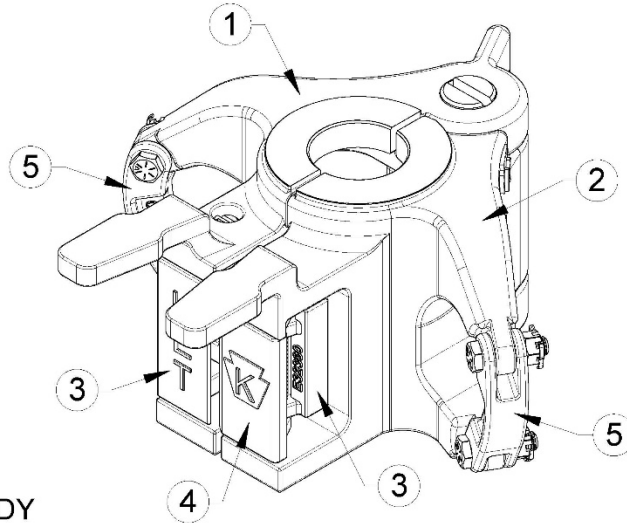

- 1. ELEVATOR BODY
- 2. ELEVATOR DOOR
- 3. LATCH
- 4. LATCH LOCK
- 5. LINK BLOCKS

UNLESS OTHERWISE SPECIFIED: MACHINING DIMENSIONS: 1 PLACE DECIMAL: .000, .005 2 PLACE DECIMAL: .00, .01, .02 3 PLACE DECIMAL: .000, .005 4 PLACE DECIMAL: .000, .005 5 PLACE DECIMAL: .000, .005 ALL DIMENSIONS ARE IN INCHES.		DRAWN: C. FONTENOT DATE: 09/11/2020 APPROVED: J. RAMEY DATE: 09/11/2020 MATERIAL GRADE: -- MATERIAL HARDNESS: -- WEIGHT: 132 LBS. APPROX.	KEYSTONE ENERGY TOOLS TITLE: KET E5000S TMA ELEVATOR MAIN COMPONENTS SIZE: B FSC#NO: 337-565-4456 DWG#NO: E5000S-A SHEET: 1 OF 1
---	--	---	--

REVISIONS			
REV.	DESCRIPTION	DATE	APPROVED
0	INITIAL RELEASE	09/11/2020	J. RAMEY

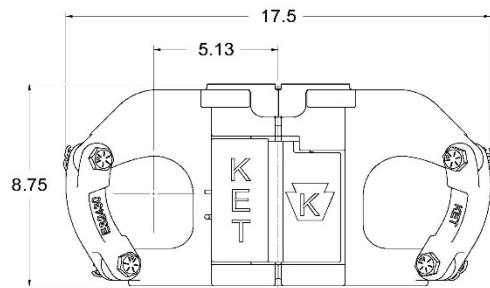
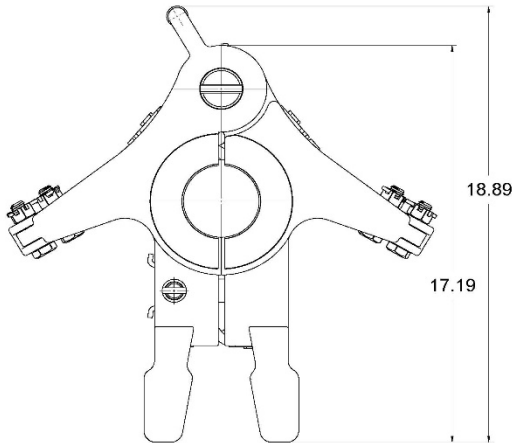

UNLESS OTHERWISE SPECIFIED: MACHINING DIMENSIONS: 1 PLACE DECIMAL: .000, .005 2 PLACE DECIMAL: .00, .01, .02 3 PLACE DECIMAL: .000, .005 4 PLACE DECIMAL: .000, .005 5 PLACE DECIMAL: .000, .005 ALL DIMENSIONS ARE IN INCHES.		DRAWN: C. FONTENOT DATE: 09/11/2020 APPROVED: J. RAMEY DATE: 09/11/2020 MATERIAL GRADE: -- MATERIAL HARDNESS: -- WEIGHT: 132 LBS. APPROX.	KEYSTONE ENERGY TOOLS TITLE: KET E5000S TMA ELEVATOR APPROXIMATE SIZE DIMENSIONS SIZE: B FSC#NO: 337-565-4456 DWG#NO: E5000S-D SCALE: 1:3 SHEET: 1 OF 1
---	--	---	--

Keystone ENERGY TOOLS

6.0 TMA Replacement Parts

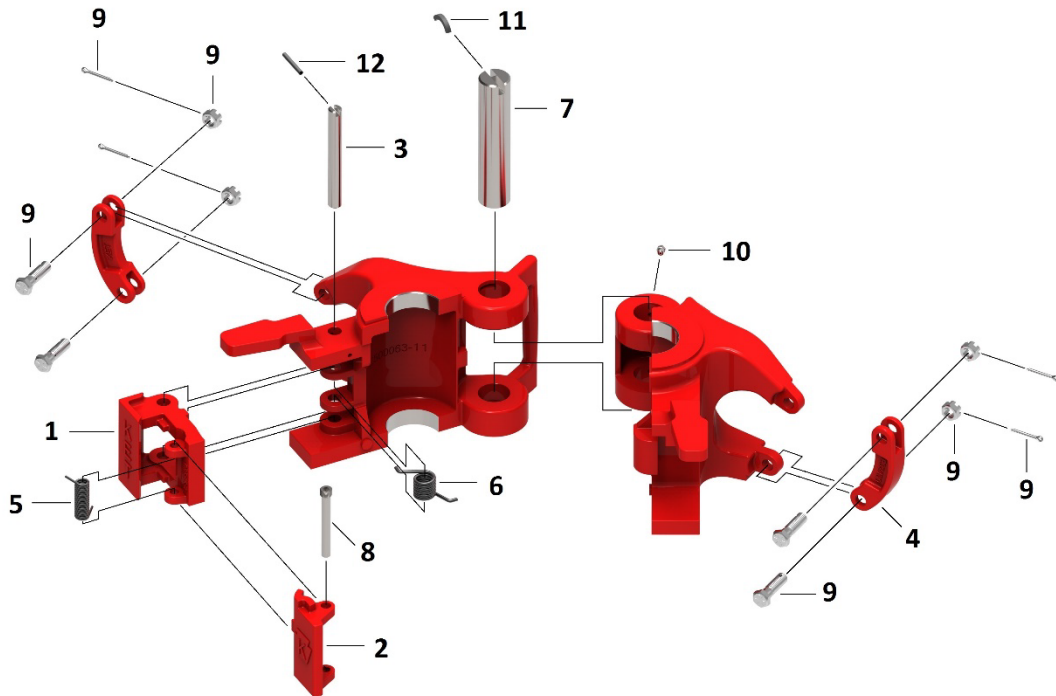

ITEM	QTY	PART No.	DESCRIPTION
1	1	E32380	LATCH
2	1	E32381-1	LATCH LOCK
3	1	E32424-1	LATCH PIN
4	2	E32430	LINK BLOCK
5	1	E32758	LATCH LOCK SPRING
6	1	E32760	LATCH SPRING
7	1	E32915	HINGE PIN
8	1	E36208	LATCH LOCK PIN
9	4	E939099-65-2	LINK BLOCK BOLT, NUT & COTTER
10	1	E940308-1	GREASE FITTING
11	1	E32916-R	HINGE PIN RETAINER
12	1	E32424-1-R	LATCH PIN RETAINER

7.0 Wear Data for TMA Elevators

PART NUMBER	E500063
RATED CAPACITY	100 TON

STANDARD PINS

HINGE PIN PART #	E32915
TOTAL CLEARANCE(H)	0.030
HINGE PIN MIN. DIA. NEW	1.743
BORE DIA.MAX. NEW	1.756
BORE DIA.MAX.WORN	1.775

LATCH PIN PART #	E32424-1
TOTAL CLEARANCE(L)	0.030
LATCH PIN MIN. DIA. NEW	0.743
BORE DIA.MAX.NEW	0.757
BORE DIA.MAX.WORN	0.776

1/16" OVERSIZE PINS

HINGE PIN PART #	E32915-R
TOTAL CLEARANCE(H)	0.030
HINGE PIN MIN. DIA.	1.805
BORE DIA.MAX. NEW	1.818
BORE DIA.MAX.WORN	1.836

LATCH PIN PART #	E32424-1-R
TOTAL CLEARANCE(L)	0.030
LATCH PIN MIN. DIA. NEW	0.805
BORE DIA.MAX.NEW	0.818
BORE DIA.MAX.WORN	0.836

1/8" OVERSIZE PINS

HINGE PIN PART #	E32915-R
TOTAL CLEARANCE(H)	.030
HINGE PIN MIN. DIA. NEW	1.868
BORE DIA.MAX. NEW	1.881
BORE DIA.MAX.WORN	1.899

LATCH PIN PART #	N/A
TOTAL CLEARANCE(L)	N/A
LATCH PIN MIN. DIA. NEW	N/A
BORE DIA.MAX.NEW	N/A
BORE DIA.MAX.WORN	N/A

LIFTING EARS

DIMENSION (W) MIN	2.750
RADIUS -R	1.625
DIMENSION (M)	5.125

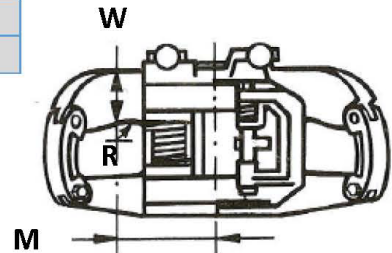
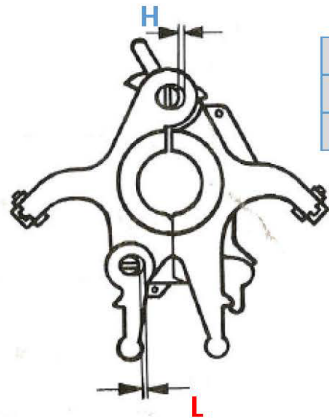

8.0 Reception, Storage, Transport & Decommissioning

Reception

Check the tool immediately after reception and re-preserve the tool as required (try to have this completed withing 1 month).

Any exposed or non painted metal surfaces should be coated with a rust preventative to prevent any corrosion build up.

Storage

The tool should be stored or palletized in a clean and dry place to avoid all environmental elements. It is recommended to store in an indoor environment of 60 – 70 Deg F with max humidity of 80%. If the tool is to be stored outdoor, then a cargo container would be appropriate to ensure the tool is not exposed to weather conditions.

Preserve the tool by greasing all areas defined in the maintenance requirements per the manual.

During storage, the tool shall still be inspected annually per inspection requirements in the user's manual.

Transport

When lifting the tool do so only by using its lifting ears only. The best way of transporting the tool is in its original palletized state. Ensure the tool is banded down accordingly to prevent the possibility of potential dropped objects and broken shipments.

Decommissioning

The tool may contain grease, steel, rubbers, plastic, stainless steel, mild steel and several assembled components with undefined consistency or mixtures. The tool can be contaminated with drilling fluids, hydraulic fluids and preservatives. After the tool is decommissioned, it is recommended to disassemble the tool in a place where waste fluids can be contained and properly disposed of.

⚠WARNING: any fluids, mud, or grease are potentially unsafe when in contact with the skin. Always wear gloves and safety goggles when disassembling the tool.

1. Clean the tool with a steam cleaner.
2. It is recommended to disassemble the tool in a place where drainage for waste fluids is possible.

CERTIFICATE OF WARRANTY AND GUARANTEE OF QUALITY

KET warrants all materials and products manufactured to be free from defects in material and workmanship, under normal use and service, when installed, used, and serviced in the manner provided and intended by the seller for a period of twelve (12) months after delivery. Seller's obligation under this warranty is expressly limited to repair or replacement, at its option, of any materials or products, returned to the seller's plant in New Iberia, Louisiana and which are determined by the seller to be defective. All freight charges for return and reshipment shall be paid by the customer. A new warranty period shall not be established for repaired or replaced material or products; such items shall remain under warranty only for the remainder of the warranty period on the original materials or products. This is the sole warranty of the seller and no other warranty is either expressed or implied, in fact or by law, including any warranty at to the merchantability or fitness for a particular use or purpose.

In case of goods or parts not wholly of seller's manufacture, seller shall make available to the customer whatever warranty or guarantee is extended to seller for such goods or parts by the supplier or manufacturer thereof.

Seller will not assume responsibility or liability for any repairs, rebuilding, welding or heat treating done to its material or products outside of seller's plant, such work shall void all warranties. All parts used in the manufacture and /or final assembly of seller's materials or products are necessary for both safety and operational performance. Omission of any part or failure to replace any worn part may result in the malfunction and a consequent safety hazard for which seller disclaims any responsibility or liability for injuries or damage as a result thereof.

Buyer's sole and only remedy in regard to any defective materials or products shall be the repair or replacement thereof as herein provided, and seller shall not be liable for any consequential, special, incidental or punitive damages resulting from or caused by any defective materials, products or supplies.



For more information, please contact us at:

Keystone Energy Tools
3711 Melancon Rd.
Broussard, LA 70518

www.k-e-t.com

Office: 1-337-365-4411
Fax: 1-337-365-4456

Revision History

Rev	Date	Changes	By
05	05/26/2021	Format change/rev history added	Cody H.
06	05/09/2022	Revised the wear data chart	Cody H.
07	07/19/2022	Address Change	Cody H.
08	04/04/2024	Added warning about shock loading	Cody H.
09	10/22/2024	Updated Wear Data (W) wrong dimension	Cody H.